



Agricultural Machines

Product Catalog for Mirror and Camera Monitor Systems

Table of contents

Agricultural Machines

Preface	05
<hr/>	
Innovations	
A Short History of Vision	08
<hr/>	
Highlights	10
<hr/>	
Development Expertise	
Guidelines	14
<hr/>	
Surround view	16
<hr/>	
Electronics expertise	18
<hr/>	
Production expertise	20
<hr/>	
Field-of-Vision Solutions for Improved Safety	
Small tractors	24
<hr/>	
Medium-sized tractors	26
<hr/>	
Large tractors	30
<hr/>	
Front-mounted implements	32
<hr/>	
Rear-mounted implements	34
<hr/>	
Trailers	36
<hr/>	
Combines	38
<hr/>	
Harvesters	40
<hr/>	
Field shredders	42
<hr/>	
Self-propelled sprayers	44
<hr/>	
Telescopic handlers	46
<hr/>	
Feed Mixers	48
<hr/>	
Forestry Machines	50
<hr/>	

Mirror Systems

Combination mirror 1036	54
Modular mirror 1009	56
Basic Line 1038	57
Compact mirror 1010	58
Wide-angle mirror 348	59
Main mirror 363	60
Wide-angle mirror 906	60
Wide-angle mirror 386	61
Main mirror 572	62
Wide-angle mirror 573	62
Close-proximity mirror 1005	63
Close-proximity mirror 552	64
Close-proximity mirror 558	65
Close-proximity mirror 559	65
Close-proximity mirror 360	66

Table of contents

Agricultural Machines

Mounting Systems

Telescopic mirror rod 1038	70
Telescopic mirror rod 1017	71
Mirror mounting system 1045	72
Mirror mounting system 1016	73
Mirror mounting system 270A/ 271	74
Wedge mounts for mirror mounting system 270A/ 271	75
Mirror mounting system 270-7	75
Mirror mounting system 1007 and 1011	76
Individual components	77

Electronics

Camera overview	80
Analog platform cameras	81
Digital platform cameras	82
Platform camera brackets	83
Shutter camera bracket	84
Monitor overview	85
Accessories	86
Appendix	87
General Terms and Conditions	88

Editorial

Dear Readers,

We are delighted to provide you with our brand new agricultural machine catalog.

As supplier of robust and high-quality indirect vision systems, we offer standard solutions as well as vehicle-specific adaptations and customized configurations based on your own designs.

Our standardized concepts and related modules enable us to provide optimized mirror and/or camera monitor systems for any type of vehicle.

We would be honored to partner with you in developing flexible and cost effective value-added solutions, and are looking forward to your inquiry.

This catalog is designed to provide you with useful information on the subject of indirect

vision and to give you a comprehensive idea of Mekra Lang's standard portfolio. As a next step, we would be happy to talk with you about your specific needs in this area and to offer you highly customized systems perfectly tailored to your requirements.

You will find that this catalog contains numerous innovations. These innovations are based on our long-standing expertise and commitment to the development of pragmatic solutions in the field of indirect vision.

You will also find that our reliable products do not only provide considerable added value but also fundamental benefits for your daily operations.

We look forward to being by your side as you meet your present and future challenges.

With kind regards,



Michael Heckel
Head of Sales OFF ROAD





Innovations

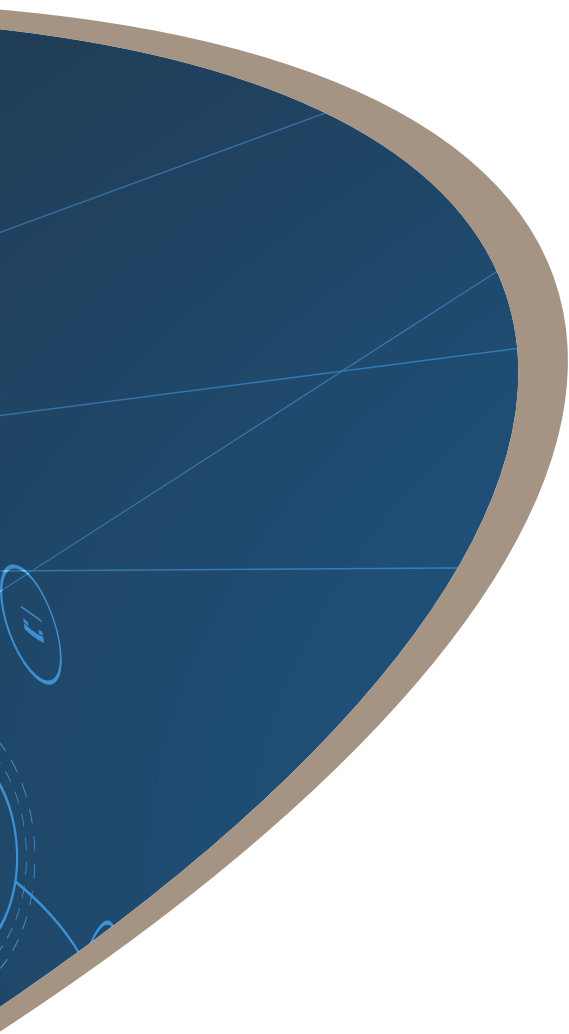

A Short History of Vision **08**

Highlights **10**

A Short History of Vision

Toward A New Dimension

Vision 1.0 – Direct Vision

Daily farm work in the 19th century was characterized by hard physical labor. Just about every task was performed by hand and the use of any kind of machinery was a rarity. Some of the work was facilitated by using horses and horse-drawn carts, and the visibility requirements both in the field and on the the road were still sufficiently met by direct vision.



Vision 2.0 – Emergence of Mechanization

During the 20th century, farm life changed fundamentally. Gradually, manpower and horsepower were replaced by machines. The widely welcomed introduction of the agricultural tractor, which would quickly prove to be indispensable to the farming community, sparked the invention of a range of additional useful farm vehicles. These developments had a significant impact on the vision requirements for

agricultural vehicles. Rather than using direct vision, as had been adequate for centuries, mirrors were now employed to monitor the areas around vehicles indirectly.



Vision 3.0 – Increase in Machine Complexity

In the late 1960s, based on decades of experience in the area of mirror production, MEKRA Lang took up manufacturing rear-view and exterior mirrors for the commercial vehicle industry. As agricultural vehicles became ever larger and more complex, obstructed vision presented more and more of a problem, placing an extreme burden on drivers and raising safety concerns for machine operators. New approaches to ensure adequate visibility in agricultural settings needed to be developed. MEKRA Lang answered the call by initiating its in-house development of camera monitor systems while continuing

to optimize its mirror portfolio. This added a critical element to indirect vision solutions, ensuring true 360° visibility around machines. By optimizing the visualization of hazardous areas, MEKRA Lang camera monitor systems enable operators to work safely and much more efficiently. With our 80 years of development expertise and our commitment to the continuous optimization of machine operations by improving visibility, we have now entered a new dimension of visualizing the work space.



Vision 4.0 – Entering A New Dimension

Vision 4.0 is a mirror replacement system for vehicles that uses HDR cameras and monitors exclusively for the first time. All viewing areas are combined and displayed on just one monitor on each side of the cab. By providing the driver with considerable assistance in operating the vehicle, the new Digital Vision System (DVS) offers important additional safety benefits, such as faster detection of environmental conditions, better assessment of hazardous situations, and significantly improved night vision thanks to using particularly sensitive cameras. Additionally, the system's better flexibility in terms of camera placement adds a new dimension to vehicle design.

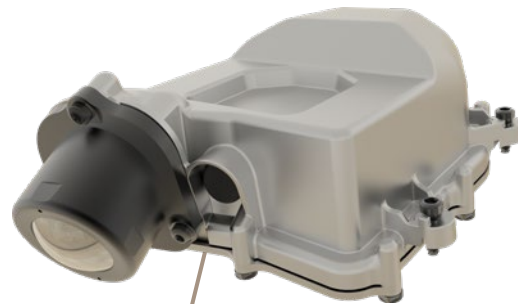

Digital Vision System (DVS)
by MEKRA Lang



Highlights

Mirror and Mounting Systems

Combination mirrors



- Optimized field-of-vision layout according to ISO 5721 for medium-sized and large agricultural tractors
- Vertical and horizontal tube connections
- Compatible with tube diameters between 22 and 28 mm
- Fully customizable design
- Various configuration options
- Adaptable to all common tractor models

For a detailed description, please see page 56

Basic Line



- Continuous field-of-vision from close proximity to horizon
- Obstacles and persons are detectable in close proximity
- Reduces risk of injuries and property damage
- Can be mounted on tube diameters 22 mm
- Tool-free mirror glass replacement

For a detailed description, please see page 57

Highlights

Camera Monitor Systems

Platform camera



- Modular assembly kit, customized solutions to accommodate individual customer requests
- Time and cost efficient adaptation to the specific camera type
- Discrete and extremely rugged camera components
- Image resolutions from standard VGA up to 1.2 mega pixels
- Analog and digital transmission standards supported
- Various aperture angles can be combined with platform components
- High-performance integrated heating system

[For a detailed description, please see page 18 / 19](#)

Telescopic mirror arm with entry light



- Identical mounting hole layout for manual and electrical models
- Rugged, corrosion-resistant design
- Quick adjustment
- Easy assembly
- Illumination of the entry area

[For a detailed description, please see page 71](#)

Mounting system



- Integrated cable routing
- Rugged, corrosion-resistant design
- Easy assembly
- Mounting hole layout identical to telescopic mirror arm 1017
- Horizontal or vertical tube connection

[For a detailed description, please see page 70](#)

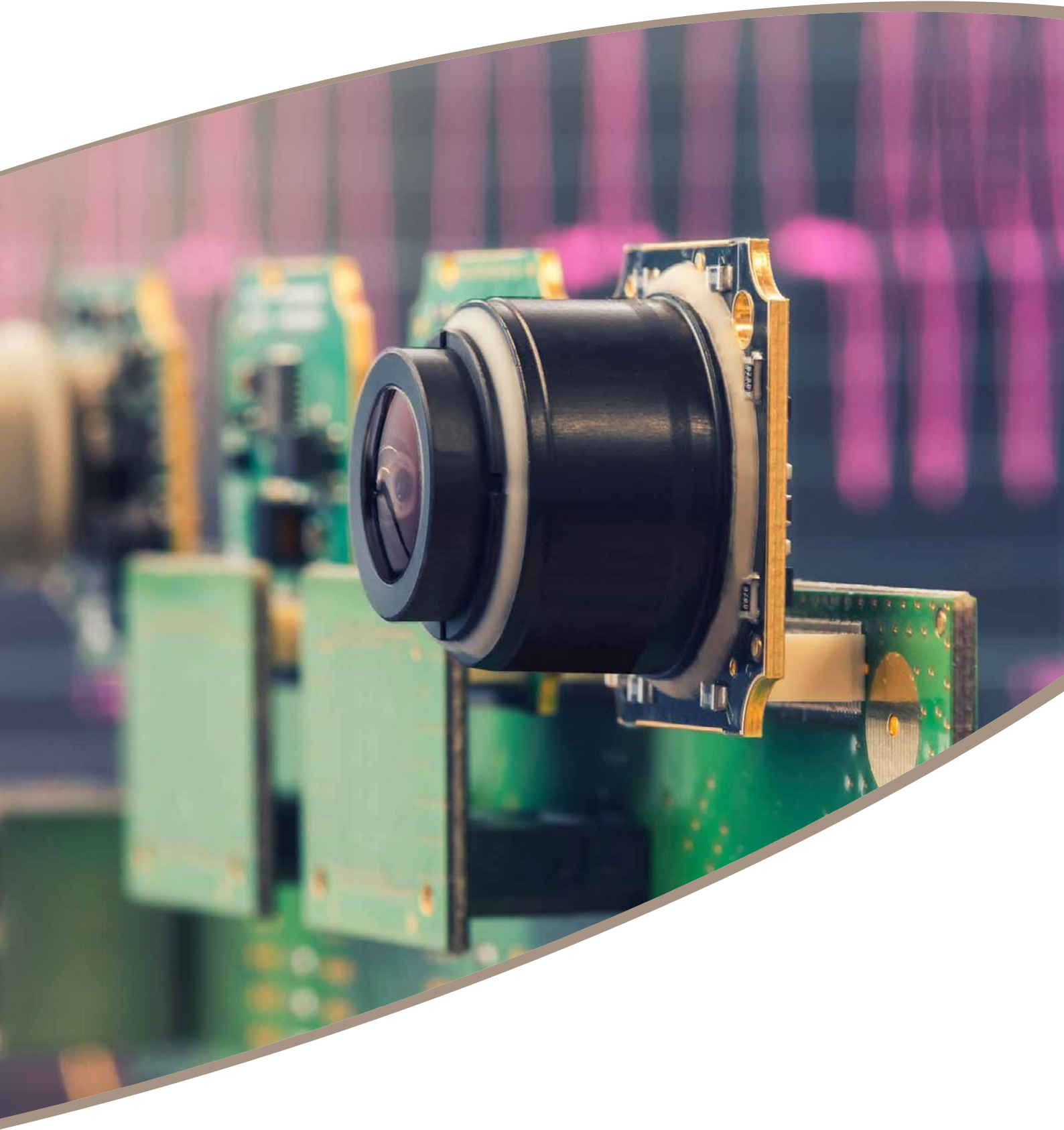

Development Expertise



Guidelines	14
Surround view	16
Electronics expertise	18
Production expertise	20

Guidelines

Overview of Current Regulations

EU 167/2013 – Directives for agricultural tractors

As of January 1, 2016, EU Regulation 167/2013 on the approval and market surveillance of agricultural and forestry vehicles will replace Directive 2009/59/EC which has been relevant for approval purposes thus far.

This means that all agricultural tractors requiring approval must meet the provisions of this directive. For more information on fields of vision and related safety

issues around the vehicle, please refer to ISO standard 5721-2 which was published in the spring of 2014. This standard takes into account the dramatic changes that the technical design of agricultural tractors has undergone during the past decades in terms of size, speed, areas of application and implements used.

The standard published by the International Organization for Standardization (ISO)

provides precise field-of-vision guidelines regarding the so-called main rear-view mirror as well as a newly added auxiliary mirror for monitoring the area next to the two rear wheels of standard agricultural tractors.

A vehicle equipped with such a system ensures maximum safety both when used in street traffic and when used for performing daily farm tasks.

Main mirror field-of-vision requirements to the rear of the tractor

From the operator's eye point, the rear view on both sides must start at a distance of 4 meters and a height of 1 meter and must expand to a width of 5 meters at a distance of 30 meters in the direction of the horizon.

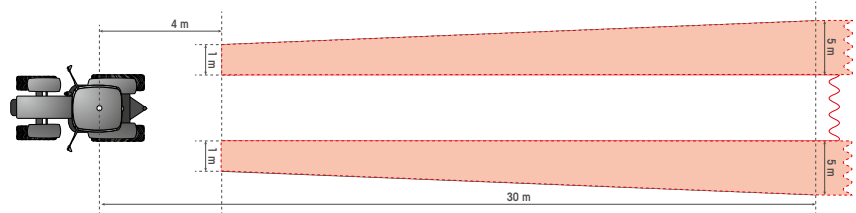

Close-proximity mirror field-of-vision requirements to the side of the tractor

Again from the operator's eye point, the view must start at 0.5 meters to the side of the vehicle at a height of 1 meter and continue on outward for another 1.5 meters, i.e. up to a vehicle distance of 2 meters.

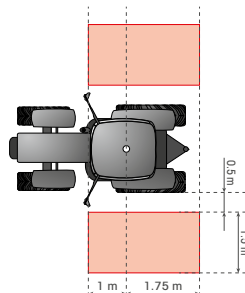

At the same time, starting at the height of the eye point, this field of vision must extend by 1.75 meters to the rear and by up to 1 meter to the front. Both field-of-vision requirements are not only met but also clearly exceeded by MEKRA Lang's new modular mirror. This is why the German Agricultural Association (DLG) in its 2011 test report 6039F characterized our mirror as a „significant safety plus...“ and deemed it „... highly recommendable“!

Derived fields of vision:

- Standard mirror field of vision
- MEKRA Lang main mirror field of vision
- MEKRA Lang close-proximity mirror field of vision

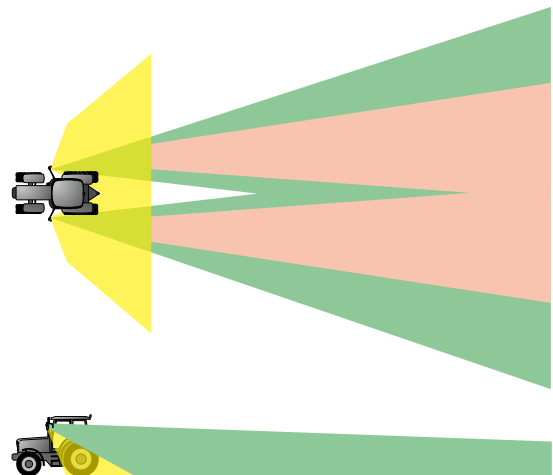

Field-of-vision studies

Using virtual vehicle models, MEKRA Lang conducts realistic field-of-vision studies in-house, ensuring the development of optimized vision systems adapted to individual, vehicle-specific characteristics, such as body shape and cab layout, providing proven safety benefits for everyday applications.

We work with systems that can help you identify potential field-of-vision obstructions early in the development process and show you ways to offset these problems using mirror and camera systems.

www.reknow.de/emm-check/emm-check

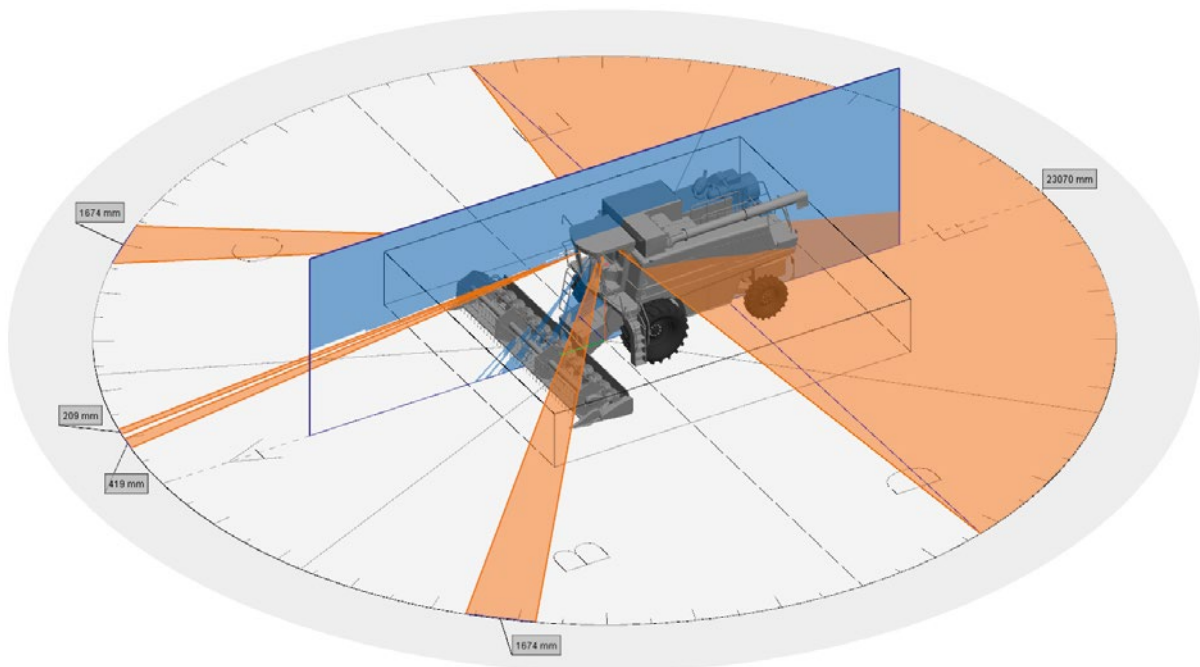

MEKRA Lang surround vision systems

The development of surround vision systems is our key competency, and it is our goal to increase work and traffic safety as well as to improve efficiency and performance. To this end, MEKRA Lang offers a product portfolio that is as diverse and versatile as its many areas of application. In individual cases, the components must be selected based on the special characteristics of the respective agricultural machines.

Our highly qualified customer service representatives will help you select a surround vision system that is a perfect match for your agricultural machine requirements and to find the most efficient solution for you.

Call on us – we love a challenge!



Visibility solution
increased efficiency
safety at work

Surround view

Single-unit Vehicle

Everything at a glance: MEKRA Lang's surround view system provides 360° vision by combining our extremely rugged cameras, which have been tried and tested for years, with a new generation of monitors.

It is up to the driver to configure the display of the individual camera images manually or to have this done automatically by using the vehicle's signals as triggers. This provides optimum visibility in critical areas for the respective viewing requirements: front camera, a combination of side and rear view cameras, or complete surround view.

In order to merge the camera images, the system does not have to rely on a control unit that requires calibration during initial installation. Furthermore, no new "blind spots" are created when dealing with complex machine configurations.



Specifications overview

Kamera

Image display	720 x 486 pixels
Ingress protection	IP 69 K
Operating temperature	-40 °C to +85 °C



Monitor

Resolution	800 x 480 pixels
Ingress protection	IP 65
Operating temperature	-30 °C to +85 °C
Operating voltage	10 - 36 V



Sample system configuration:

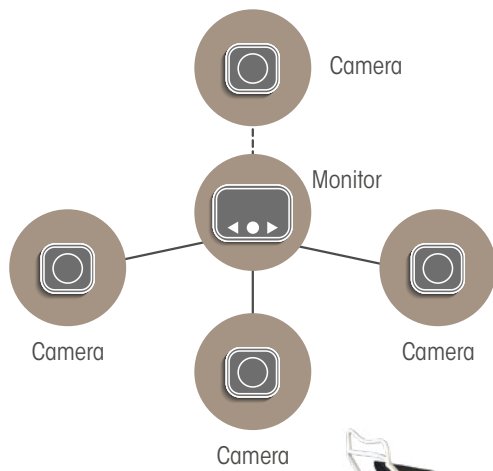

Electronics Expertise

Modular Vision Solution for Analog and Digital Applications

The platform concept

Aperture angle selection

We will consult with you to determine the field of vision and the corresponding aperture angle required for your application.



Image processing

Image processing parameters vary depending on the intended purpose of the application. The platform concept makes customization easy and cost efficient.



Transmission set-up

Whether digital or analog, each transmission type has its specific advantages and each application requires the appropriate connection set-up. These factors, too, are accommodated quickly and efficiently.



The benefits of modularity

The MEKRA Lang platform camera and its high-quality components are characterized by a high degree of modularity which enables us to offer customized camera solutions perfectly adapted to our customers' preferences.

The camera is particularly well suited for machine applications in the fields of agriculture and construction. Thanks to its modular design, the camera can be adapted to any vehicle type quickly and cost efficiently.

The individual camera components are extremely robust and compact in size (35 x 35 mm). The length of the camera varies with the individual models, however, the minimum length of every model is 34 mm which makes it easy to integrate and attach almost anywhere in or on the vehicle. The modular design allows for a wide variety of image sensors

as well as image processing and transmission technologies to be combined, providing a customized and cost effective solution uniquely adapted to the individual needs of the customer.

The available image sensors are automotive-grade and offer image resolution from standard VGA up to 1.2 mega pixels. The image processor is matched to the performance characteristics of the specific image sensor. Transmission technology options include analog PAL or NTSC based video transmission as well as digital transmission standards, such as Fast Ethernet, BroadR-Reach and LVDS.

It is also possible to combine various lenses with different horizontal aperture angles in the platform components.

Aperture angles for analog options include 70°, 100°, and 120°, and for digital options 100°, 120°, 160°, and 176° (wider aperture angles are also supported).

The MEKRA Lang platform camera features a particularly rugged housing which makes it perfectly suited for rough environmental conditions. And thanks to its high-performance integrated heating system, the camera can be operated in any weather.

Digitization enables new types of application

Digital data transmission allows for significantly higher image resolution. Several cameras connected to a vehicle network share one single data connection from switch to display. This

results in significantly reduced wiring requirements. The connection does not only support the transmission of image data but also of various other control signals for the camera, such as activation of the cleaning system.

In the future, added value will be generated by supporting additional systems based on the analysis of digital data collected from the camera's sensor chip.

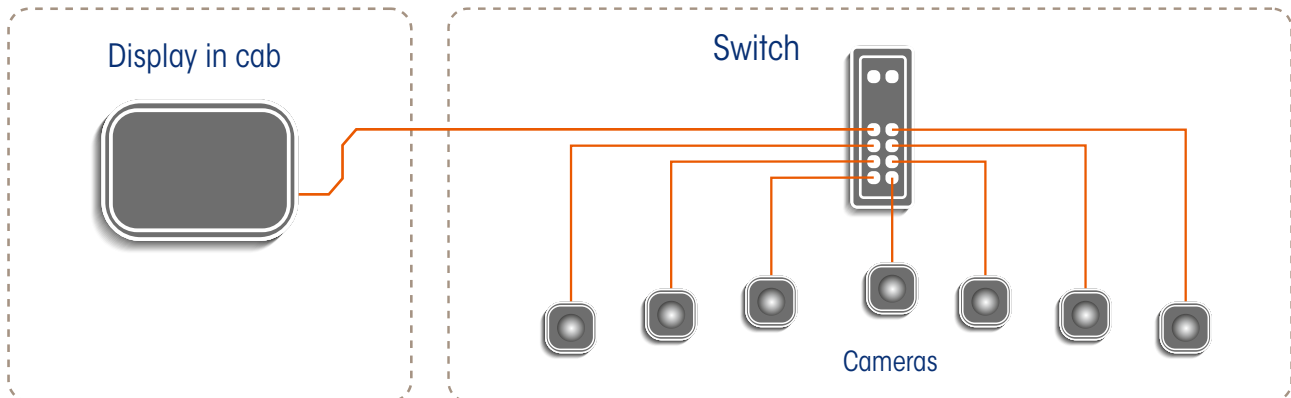

Specifications overview

Digital Ethernet camera

Dimensions	35 x 35 x 49 mm (W x H x D)
Ingress protection	IP 69 K
Operating temperature	-40 °C to +85 °C
Operating voltage	9 - 36 V
Aperture angle (hor.)	100°, 120°, 160° or 176°
Image sensor	1.2 mega pixels
Image resolution	1280 x 720 pixels
Video transmission	RTP
Video compression	MJPEG or H.264



Analog camera

Dimensions	35 x 35 x 34 mm (W x H x D)
Ingress protection	IP 69 K
Operating temperature	-40 °C to +85 °C
Operating voltage	9 - 36 V
Aperture angle (hor.)	70°, 100° or 120°
Image sensor	VGA
Image resolution	640 x 480 pixels
Video transmission	PAL or NTSC



Production Expertise

Customer Satisfaction, Vertical Integration, and Global Footprint

All activities within the MEKRA Lang production areas follow and apply basic „Lean Thinking“ principles and the associated methods of value creation focusing on error-free, customer-centric and flowing business processes. It is our goal to raise our employees' awareness of these issues,

both in Germany and internationally. All of us working for the Lang Group are united in striving for continuous improvement of our workflows and processes with customer satisfaction at the center of everything we do. Thanks to the incremental improvement of our system as a whole based on

cutting-edge insights and technological advances we are able to add value in the interest of our customers and to offer high-quality and flawless „just in time“ delivery.

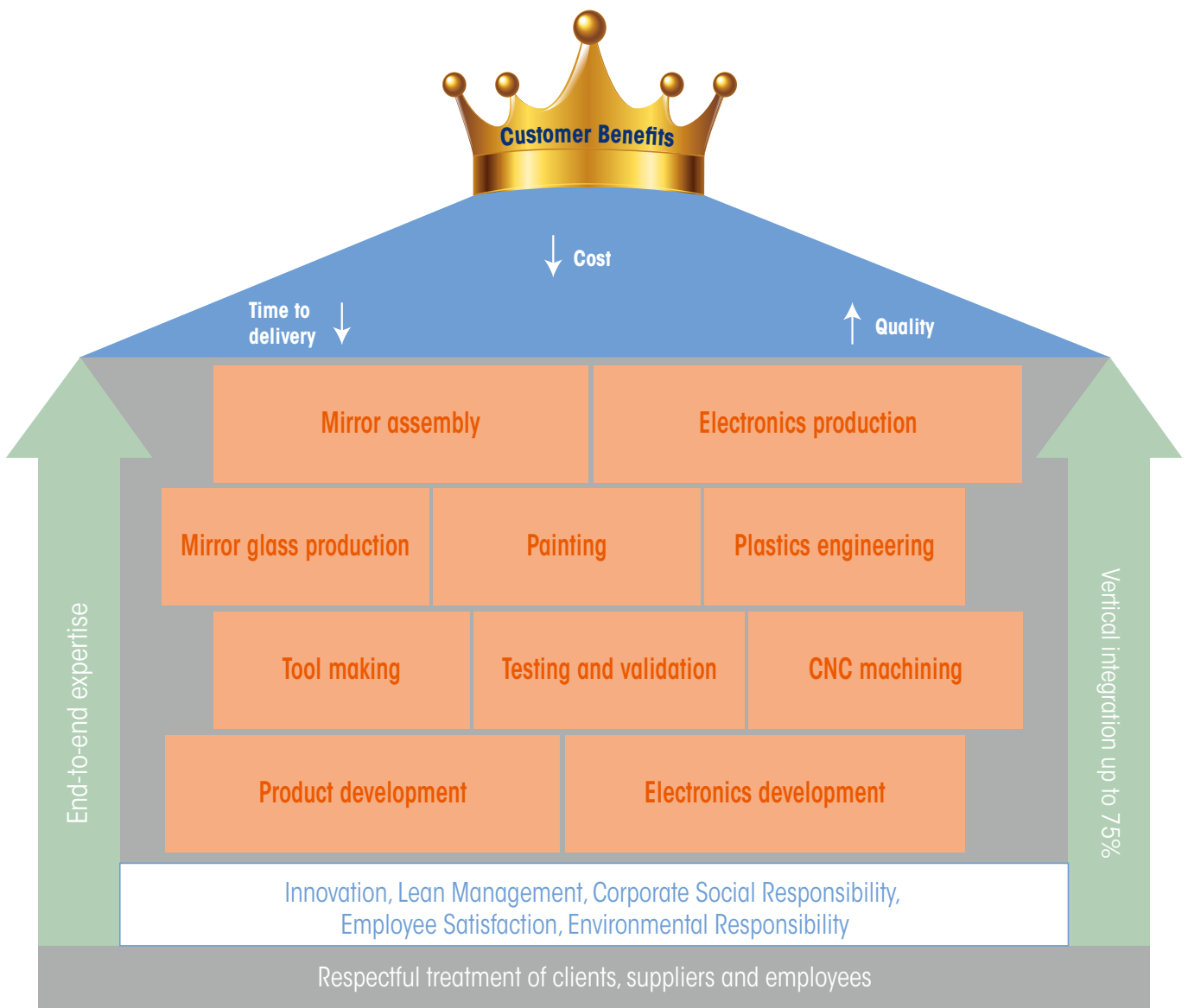

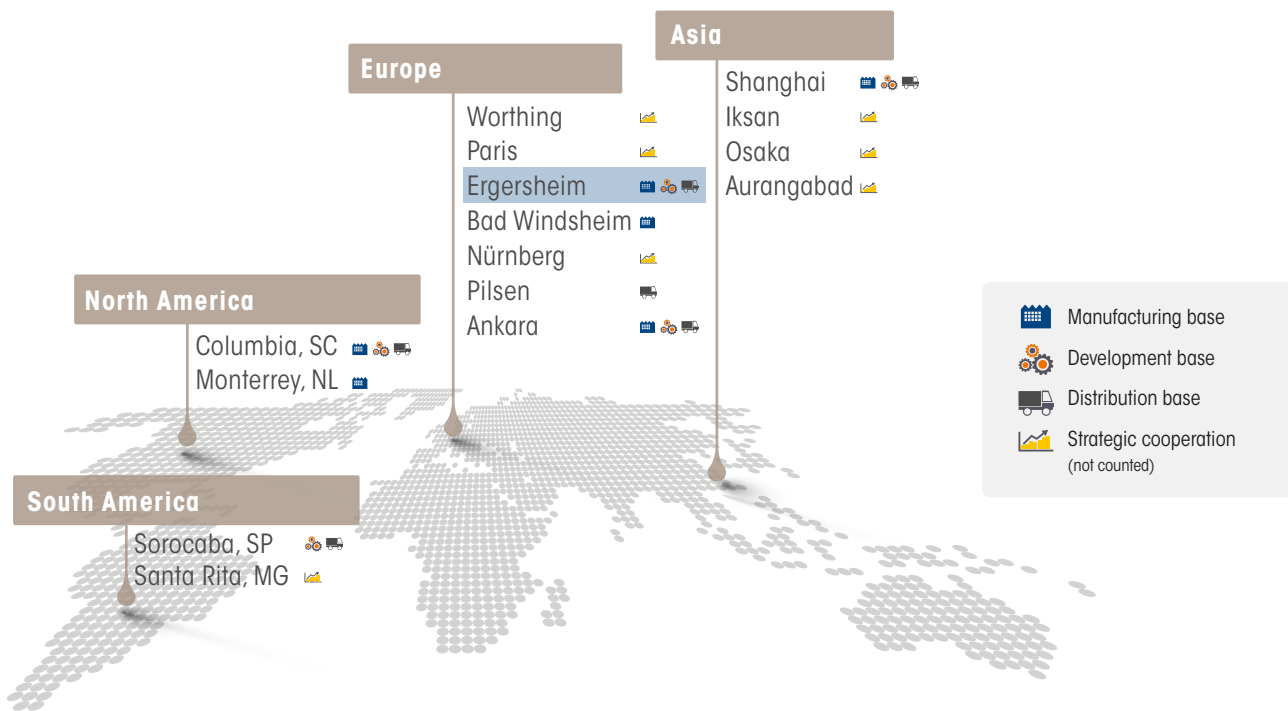

Bringing all departments to the table to collaborate on the development of new product and manufacturing concepts has always been very beneficial for us. It involves testing various product requirements and processes in a team setting early on in the development phase and clears the track for implementing our common goal. We can identify and leverage opportuni-

ties in a timely manner thereby ensuring a smooth ramp-up to production.

Depending on the location of our production facilities and underlying conditions, we adapt our shop floor configuration to the specific task at hand. This enables us to optimize our assembly lines for the production of the durable and versatile

products typically required for agricultural applications and gives us great flexibility to respond to customer requests, even with small production units. The Lang Group operates production facilities all around the world, which means that we can use our expertise to implement almost all projects in close proximity to our customers.



**Field-of-Vision Solutions
for Improved Safety**



	Small tractors	24
	Medium-sized tractors	26
	Large tractors	30
	Front-mounted implements	32
	Rear-mounted implements	34
	Trailers	36
	Combines	38
	Harvesters	40
	Field shredders	42
	Self-propelled sprayers	44
	Telescopic handlers	46
	Feed Mixers	48
	Forestry Machines	50

Field-of-Vision Solutions

Small Tractors



1

1016
Spiegel-Haltesystem



1038
Basic Line

2

1016
Spiegel-Haltesystem



1038
Basic Line

Standard solution

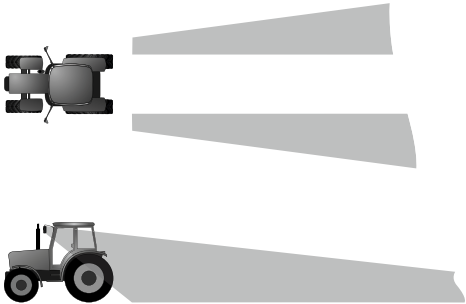

MEKRA Lang solution



MEKRA Lang mirror systems

Product #	Item Name	Page
1038	Basic Line, left or right side, 1200 / 200 mm radius of curvature	57
1016	Mirror mounting system, left side, 22 mm dia.	73
1016	Mirror mounting system, right side, 22 mm dia.	73

The systems shown are recommended by MEKRA Lang.
Beginning on page 56, you will find additional MEKRA Lang product solutions and alternatives.

Field-of-Vision Solutions

Medium-sized Tractors



1

1038
Mounting system



1009
Modular mirror

2

1038
Mounting system



1009
Modular mirror

Standard solution

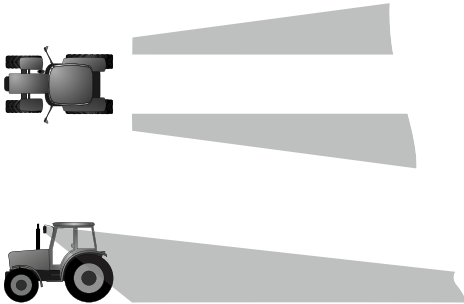

MEKRA Lang solution



MEKRA Lang mirror systems

Product #	Item name	Page
1009	Modular mirror incl. close-proximity mirror, left and right side, 1200/240 mm radius of curvature, manual adjustment or ELST	56
1038	Mounting system, 22 mm dia.	70
1038	Mounting system, 22 mm dia.	70

The systems shown are recommended by MEKRA Lang.
Beginning on page 56, you will find additional MEKRA Lang product solutions and alternatives.

Field-of-Vision Solutions

Medium-sized Tractors



1

1017
Telescopic mirror arm



1009
Modular mirror

2

1017
Telescopic mirror arm



1009
Modular mirror

Standard solution

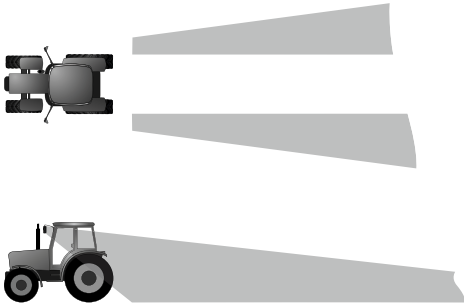

MEKRA Lang solution



MEKRA Lang mirror solution

Produkt-Nr.	Artikelbezeichnung	Seite
1009	Modular mirror incl. close-proximity mirror, left and right side, 1200/300 mm radius of curvature, manual adjustment or electrical/heated	56
1017	Telescopic mirror arm, left side, manual adjustment, 22 mm dia.	71
1017	Telescopic mirror arm, right side, manual adjustment, 22 mm dia.	71

The systems shown are recommended by MEKRA Lang.
Beginning on page 56, you will find additional MEKRA Lang product solutions and alternatives.

Field-of-Vision Solutions

Large Tractors



3

MCM monitor



1

1017

Telescopic mirror arm



1036

Combination mirror

2

1017

Telescopic mirror arm



1036

Combination mirror

4

MCC side view camera



5

MCC front and rear view camera



Standard solution

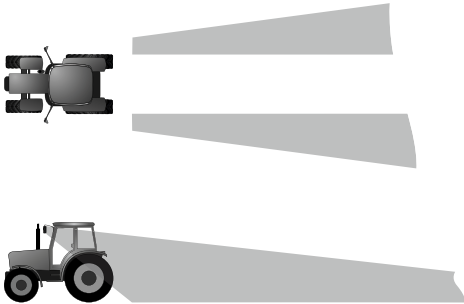

MEKRA Lang solution

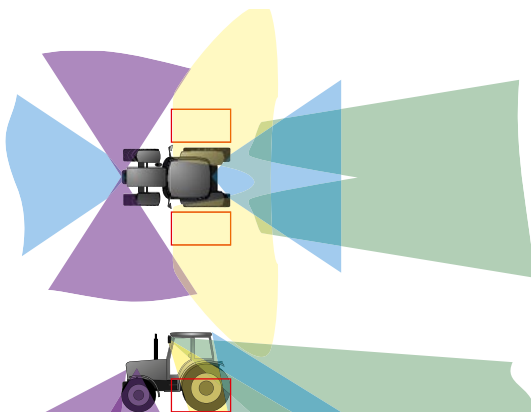

Visibility solution
increased efficiency
safety at work

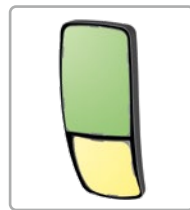

MEKRA Lang mirror and camera monitor systems

MEKRA Lang mirror system

Product #	Item name	Page
1036	Combination mirror incl. close-proximity mirror, left and right side, 1200/300 mm radius of curvature, electrical adjustment, heated, 12 V	54
1017	Telescopic mirror arm, left side, electrical adjustment, 22 mm dia. with LED	71
1017	Telescopic mirror arm, right side, electrical adjustment, 22 mm dia. w/o LED	71

MEKRA Lang camera monitor system

Product #	Item name	Page
MCM	7" TFT monitor, 4 camera inputs	85
MCC	Front and rear view camera, 120° CMOS color camera (platform basis)	81
MCC	Side view camera, 70° CMOS color camera (platform basis)	81
MCC	Side view camera, 70° CMOS color camera (platform basis)	81

The systems shown are recommended by MEKRA Lang.
Beginning on page 56, you will find additional MEKRA Lang product solutions and alternatives.

Field-of-Vision Solutions

Front-mounted Implements



Standard solution

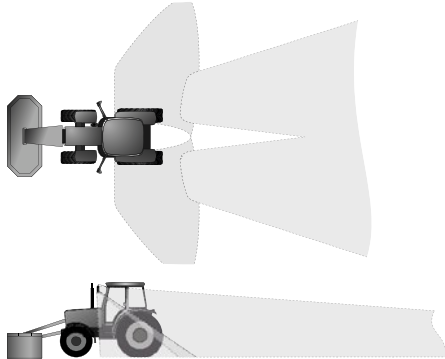

MEKRA Lang solution

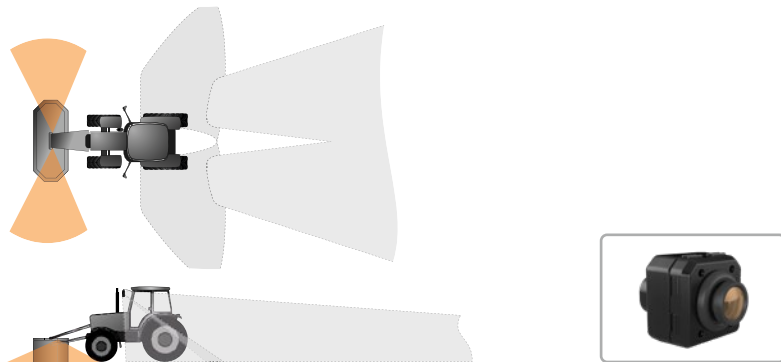

MEKRA Lang camera monitor systems

Product #	Item Name	Page
MCM	MEKRA 7" digital monitor, 4 camera inputs	85
MCC	Front camera, 70° CMOS color camera	81
MCC	Front camera, 70° CMOS color camera	81

The systems shown are recommended by MEKRA Lang.
Beginning on page 80, you will find additional MEKRA Lang product solutions and alternatives.

Field-of-Vision Solutions

Rear-mounted Implements



1

MCM monitor



2

MCC
rear view camera



3

Magnetic base



Standard solution

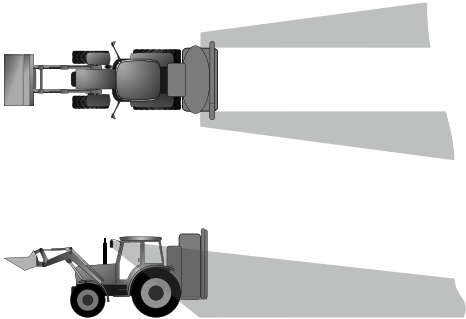

MEKRA Lang solution

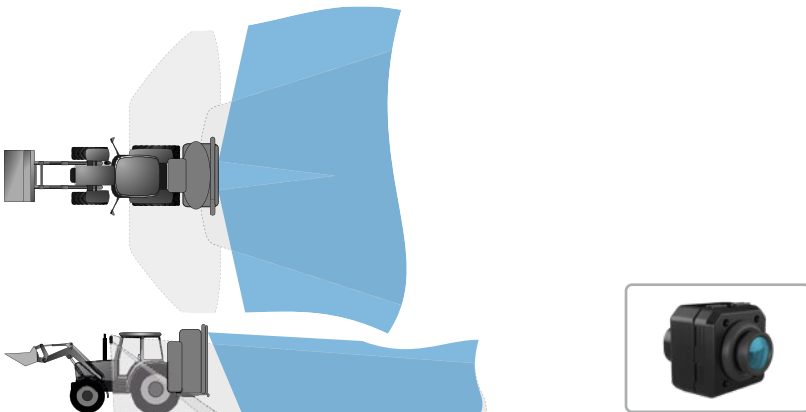

MEKRA Lang camera monitor systems

Product #	Item name	Page
MCM	7" TFT monitor, 4 camera inputs	85
MCC	Rear view camera, 120° CMOS color camera (platform basis)	81
MMB	Magnetic base for camera bracket	83

The systems shown are recommended by MEKRA Lang.
Beginning on page 80, you will find additional MEKRA Lang product solutions and alternatives.

Field-of-Vision Solutions

Trailers



1

MCM monitor



2

MAC
direct connecting cable



3

MAC
adapter cable



4

MAC
adapter cable



5

MCC
rear view camera



Standard solution

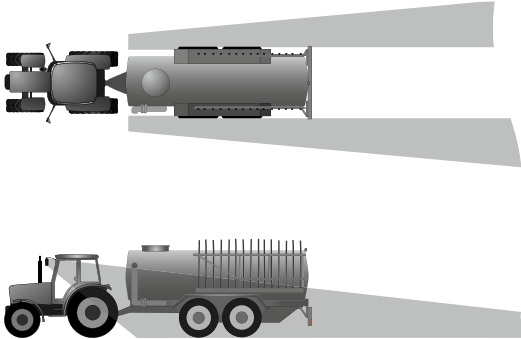

MEKRA Lang solution

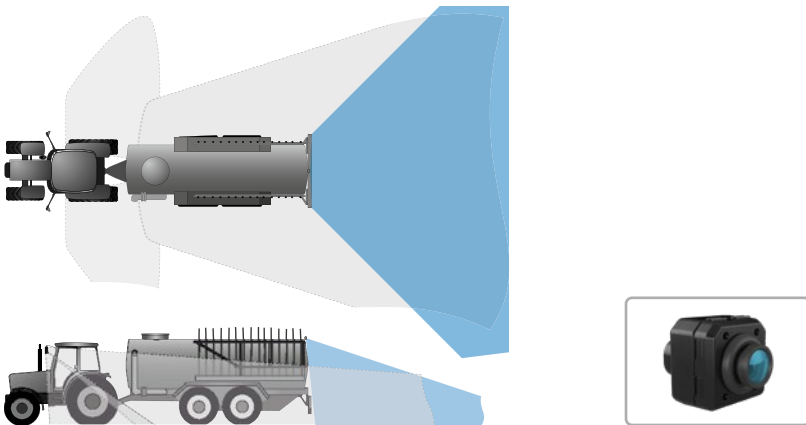

MEKRA Lang camera monitor systems

Product #	Item Name	Page
MCM	7" TFT monitor, 4 camera inputs	85
MAC	Direct connecting cable AMP-MEKRA (m-f) 5 m	86
MAC	Adapter cable MEKRA-ABS (m-m) 0.5 m	86
MAC	Adapter cable ABS-MEKRA (f-f) 11 m	86
MCC	Rear view camera, 120° CMOS color camera (platform basis)	81

The systems shown are recommended by MEKRA Lang.
Beginning on page 80, you will find additional MEKRA Lang product solutions and alternatives.

Field-of-Vision Solutions

Combines

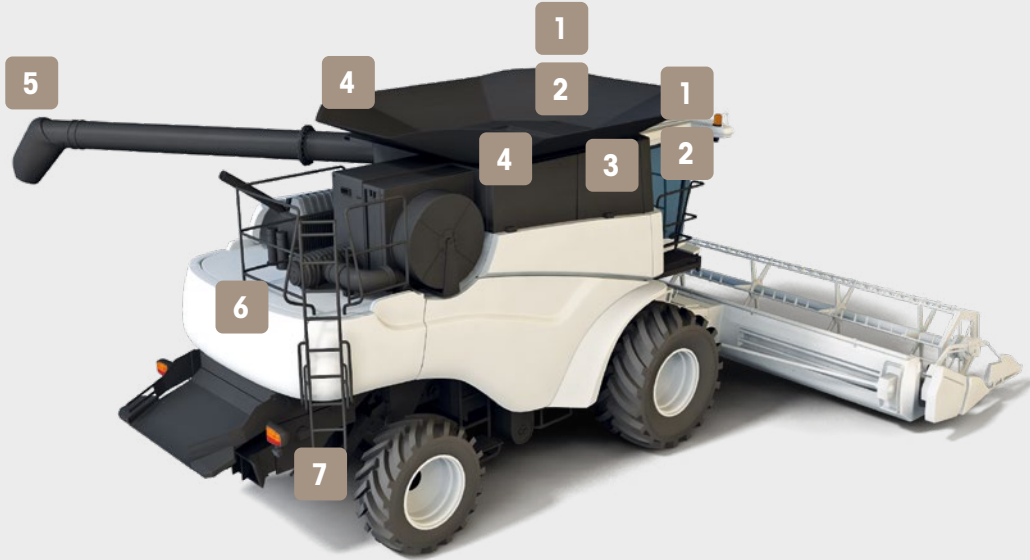

1

1011
Mirror mounting system

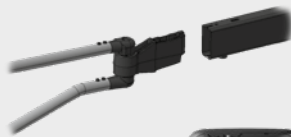

363
Main mirror



386
Wide-angle mirror



2

558
Close-proximity mirror



3

MCM Monitor



4

MCC side view camera



5

MCC transfer camera



6

MCC rear view camera



7

MCC trailer camera



Standard solution

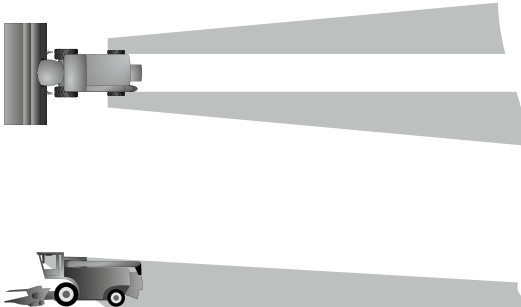

MEKRA Lang solution

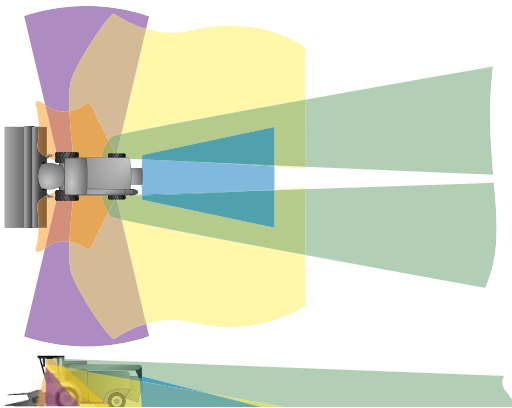

Visibility solution
increased efficiency
safety at work



MEKRA Lang mirror and camera monitor systems

MEKRA Lang mirror system

Product #	Item name	Page
363	Main mirror, left and right side, 1200 mm radius of curvature, electrical adjustment, heated, 12 V	60
386	Wide-angle mirror, left and right side, 300 mm radius of curvature, electrical adjustment, heated, 12 V	61
1011	Mirror mounting system, left and right side, 28 mm dia.	76
558	Close-proximity mirror, left and right side, 300 mm radius of curvature, heated, 12 V	65

MEKRA Lang camera monitor system

Product #	Item name	Page
MCM	7" TFT monitor, 4 camera inputs	85
MCC	Transfer camera, 100° CMOS color camera, low dist. (platform basis)	81
MCC	Rear view camera, 120° CMOS color camera (platform basis)	81
MCC	Trailer camera, 70° CMOS color camera (platform basis)	81
MCC	Side view camera, 100° CMOS color camera (platform basis)	81

The systems shown are recommended by MEKRA Lang.
Beginning on page 56, you will find additional MEKRA Lang product solutions and alternatives.

Field-of-Vision Solutions

Harvester



1

1011
Mirror mounting system

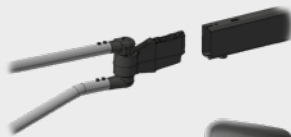

572
Main mirror



573
Wide-angle mirror



2

558
Close-proximity mirror



3

MCM monitor



4

MCC
transfer camera



5

MCC
process camera



6

MCC
rear view camera



Standard solution

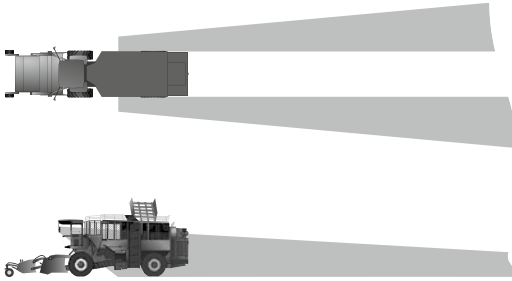

MEKRA Lang solution

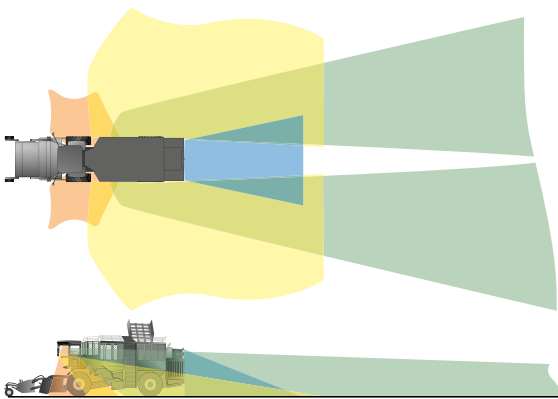

Visibility solution
increased efficiency
safety at work

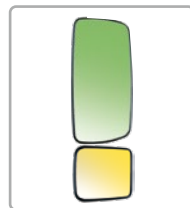

MEKRA Lang mirror and camera monitor systems

MEKRA Lang mirror system

Product #	Item name	Page
572	Main mirror, left and right side, 1200 mm radius of curvature, electrical adjustment, heated, 12 V	62
573	Wide-angle mirror, left and right side, 300 mm radius of curvature, electrical adjustment, heated, 12 V	62
1011	Mirror mounting system, left and right side, 28 mm dia.	76
558	Close-proximity mirror, left and right side, 300 mm radius of curvature, heated, 12 V	65

MEKRA Lang camera monitor system

Product #	Item name	Page
MCM	7" TFT monitor, 4 camera inputs	85
MCC	Transfer camera, 100° CMOS color camera	81
MCC	Process camera, 70° CMOS color camera	81
MCC	Rear view camera, 120° CMOS color camera	81

The systems shown are recommended by MEKRA Lang.
Beginning on page 56, you will find additional MEKRA Lang product solutions and alternatives.

Field-of-Vision Solutions

Field Shredders



1

1007
Mounting system



363
Main mirror



386
Wide-angle mirror



2

558
Close-proximity mirror



3

MCM monitor



4

MCC
side view camera



5

MCC-
Seitenkamera



6

MCC rear view
or trailer camera



7

MCC
transfer camera



Standard solution

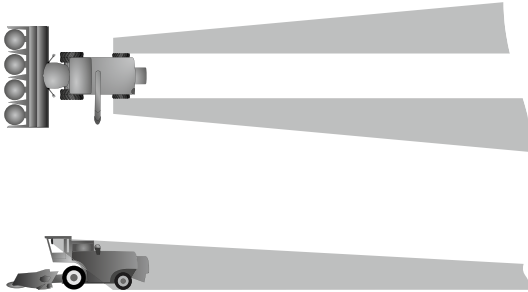

MEKRA Lang solution

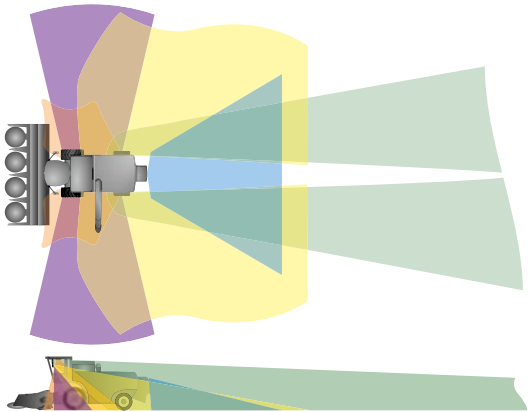

Visibility solution
increased efficiency
safety at work



MEKRA Lang mirror and camera monitor systems

MEKRA Lang mirror system

Product #	Item name	Page
363	Main mirror, left and right side, 1200 mm radius of curvature, electrical adjustment, heated, 12 V	60
386	Wide-angle mirror, left and right side, 300 mm radius of curvature, electrical adjustment, heated, 12 V	61
558	Close-proximity mirror, left and right side, 300 mm radius of curvature, heated, 12 V	65
1007	Mirror mounting system, left and right side, 40 mm dia.	76

MEKRA Lang camera monitor system

Product #	Item name	Page
MCM	7" TFT monitor, 4 camera inputs	85
MCC	Transfer camera, 100° CMOS color camera, low dist. (platform basis)	81
MCC	Rear view or trailer camera, 120° CMOS color camera (platform basis)	81
MCC	Side view camera, 100° CMOS color camera (platform basis)	81
MCC	Side view camera, 100° CMOS color camera (platform basis)	81

The systems shown are recommended by MEKRA Lang.
Beginning on page 56, you will find additional MEKRA Lang product solutions and alternatives.

Field-of-Vision Solutions

Self-propelled Sprayers

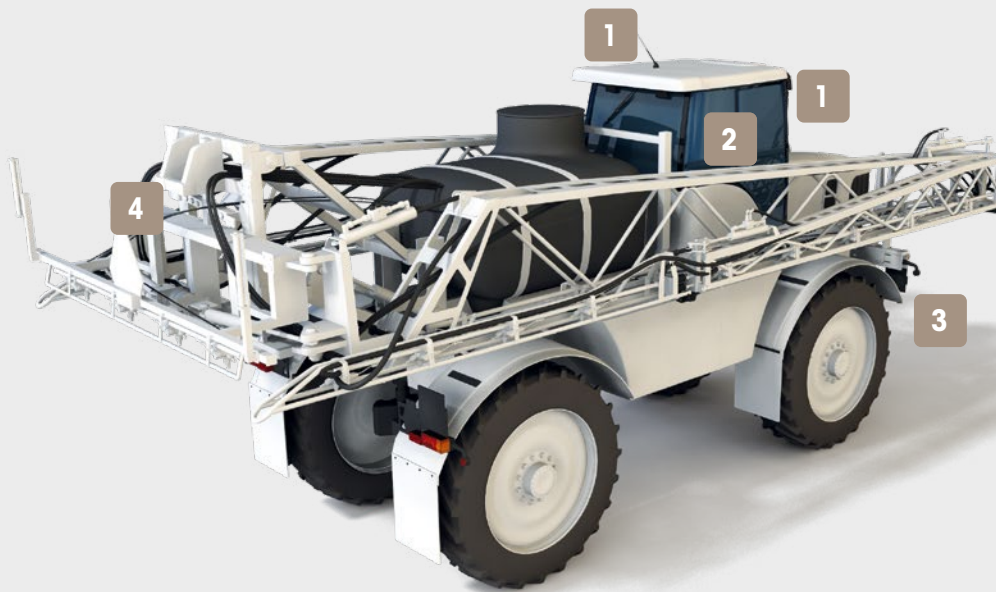

1

1017
Telescopic mirror arm



1036
Combination mirror

2

MCM monitor



3

MCC lane
detection camera



4

MCC
rear view camera



Standard solution

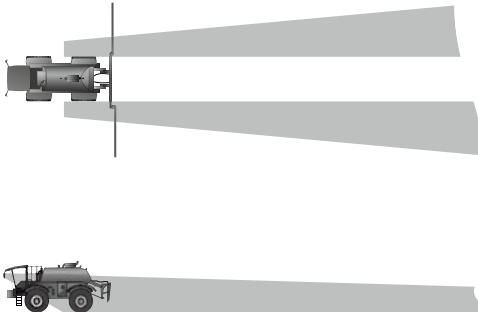

MEKRA Lang solution

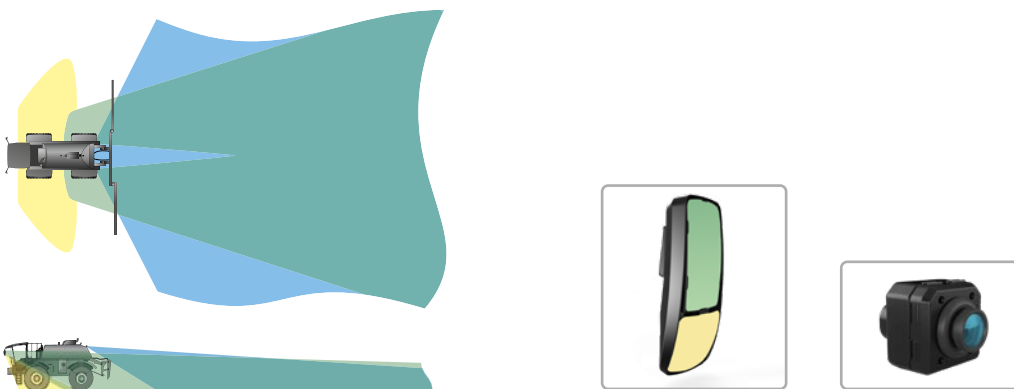

MEKRA Lang mirror and camera monitor systems

MEKRA Lang mirror system

Product #	Item name	Page
1036	Main mirror incl. close-proximity mirror, left and right side, 1200/300 mm radius of curvature, electrical adjustment, heated, 12 V	54
1017	Telescopic mirror arm, left side, electrical adjustment, 22 mm dia.	71
1017	Telescopic mirror arm, right side, electrical adjustment, 22 mm dia.	71

MEKRA Lang camera monitor system

Product #	Item name	Page
MCM	7" TFT monitor, 4 camera inputs	85
MCC	Lane detection camera, 70° CMOS color camera	81
MCC	Rear view camera, 120° CMOS color	81

The systems shown are recommended by MEKRA Lang.
Beginning on page 56, you will find additional MEKRA Lang product solutions and alternatives.

Field-of-Vision Solutions

Telescopic Handlers



1

1016

Mirror mounting system



1009

Modular mirror

2

1009

Modular mirror with extended field of vision



270-7

Mirror mounting system

3

MCM monitor



4

MCC rear view camera



5

MCC side view camera



Standard solution

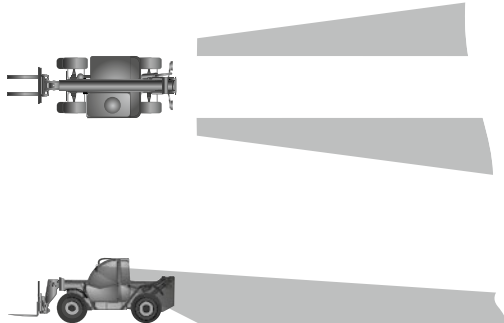

MEKRA Lang solution

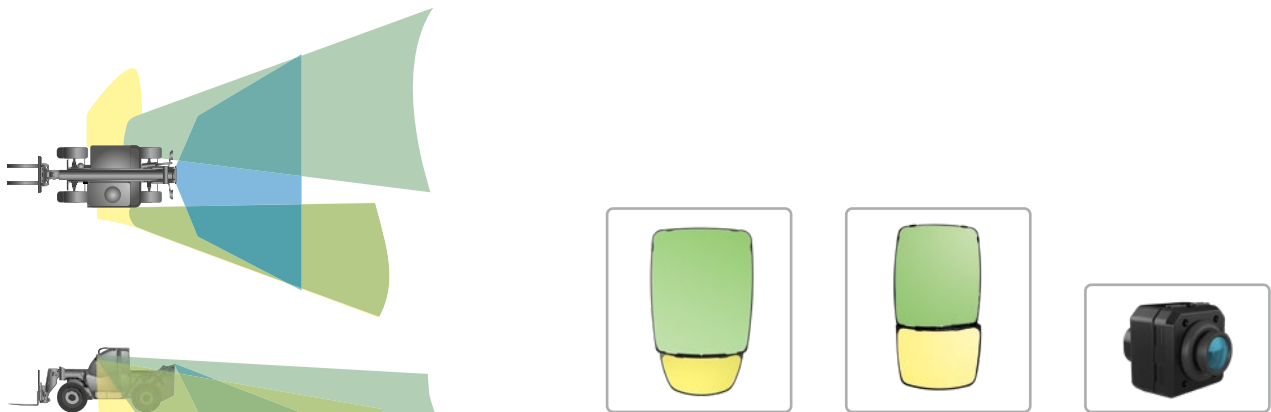

MEKRA Lang mirror and camera monitor systems

MEKRA Lang mirror system

Product #	Item name	Page
1009	Modular mirror incl. close-proximity mirror, left and right side, 1200/240 mm radius of curvature, electrical adjustment, heated, 12 V	56
1016	Mirror mounting system, left side, 22 mm dia.	73
1009	Modular mirror incl. close-proximity mirror, right side, 1200/300 mm radius of curvature, electrical adjustment, heated, 12 V	56
270-7	Mirror mounting system, right side, 28 mm dia.	74

MEKRA Lang camera monitor system

Product #	Item name	Page
MCM	7" TFT monitor, 4 camera inputs	85
MCC	Rear view camera, 120° CMOS color	81
MCC	Side view camera, 100° CMOS color	81

The systems shown are recommended by MEKRA Lang.
Beginning on page 56, you will find additional MEKRA Lang product solutions and alternatives.

Field-of-Vision Solutions

Feed Mixers



Standard solution

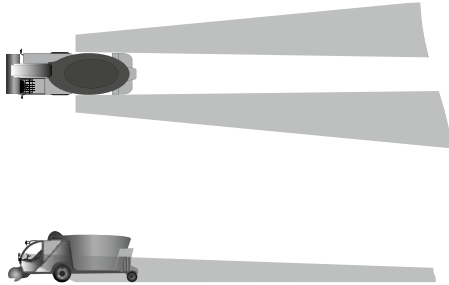

MEKRA Lang solution

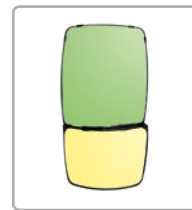
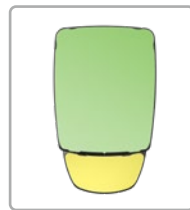
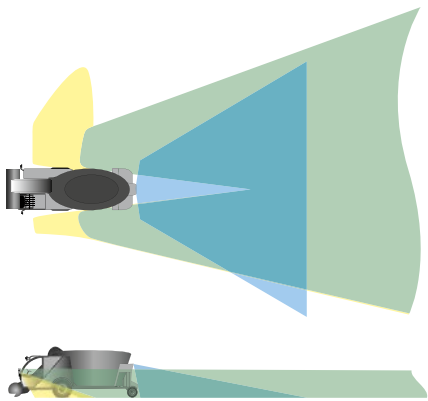

MEKRA Lang mirror and camera monitor systems

MEKRA Lang mirror system

Product #	Item name	Page
1009	Modular mirror incl. close-proximity mirror, left and right side, 1200/240 mm radius of curvature, electrical adjustment, heated, 12 V	56
1016	Mirror mounting system, left side, 22 mm dia.	73
1009	Modular mirror incl. close-proximity mirror, right side, 1200/300 mm radius of curvature, electrical adjustment, heated, 12 V	56
270-7	Mirror mounting system, right side, 28 mm dia.	74

MEKRA Lang camera monitor system

Product #	Item name	Page
MCM	7" TFT monitor, 4 camera inputs	85
MCC	Mixing tub camera, 100° CMOS color camera	81
MCC	Rear view camera, 120° CMOS color camera	81
MCC	Feed discharge camera, 100° CMOS color camera, low distortion	81

The systems shown are recommended by MEKRA Lang.
Beginning on page 56, you will find additional MEKRA Lang product solutions and alternatives.

Field-of-Vision Solutions

Forestry Machines



1

1016
Mirror mounting system



1009
Modular mirror



2

1016
Mirror mounting system



1009
Modular mirror



3

MCM monitor



4

MCC
rear view camera



Standard solution

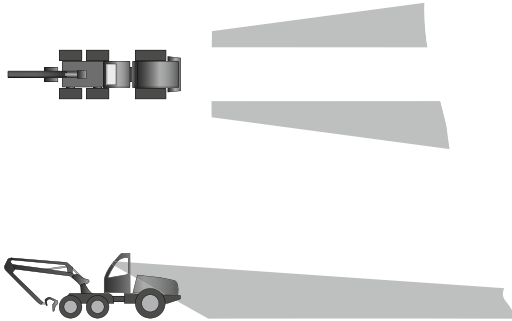

MEKRA Lang solution

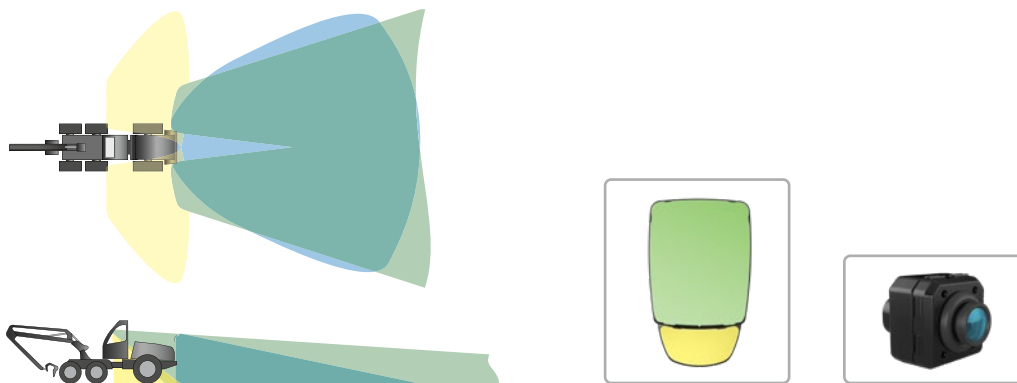

MEKRA Lang mirror and camera monitor systems

MEKRA Lang mirror system

Product #	Item name	Page
1009	Modular mirror incl. close-proximity mirror, left and right side, 1200/240 mm radius of curvature, manual adjustment, heated, 12 V	56
1016	Mirror mounting system, left side, 22 mm dia.	73
1016	Mirror mounting system, right side, 22 mm dia.	73

MEKRA Lang camera monitor system

Product #	Item name	Page
MCC	7" TFT monitor, 4 camera inputs	85
MCC	Rear view camera, 120° CMOS color camera (platform basis)	81

The systems shown are recommended by MEKRA Lang.
Beginning on page 56, you will find additional MEKRA Lang product solutions and alternatives.



Mirror Systems



Combination mirror 1036	54
Modular mirror 1009	56
Basic Line 1038	57
Compact mirror 1010	58
Main mirror 348	59
Wide-angle mirror 348	59
Main mirror 363	60
Wide-angle mirror 906	60
Wide-angle mirror 386-1	61
Main mirror 572	62
Wide-angle mirror 573	62
Nahbereichsspiegel 1005	63
Close-proximity mirror 552	64
Close-proximity mirror 558	65
Close-proximity mirror 559	65
Close-proximity mirror 360	66

Mirror Systems

Combination Mirrors



Combination mirror 1036

Glass size	Main mirror 297 x 200 mm (W x H), close-proximity mirror 176 x 190 mm (W x H)
Radius of curvature	Main mirror 1200 mm, Close-proximity mirror 300 mm
Mounting side	Right and left
Heating	Unheated or heated, 12 or 24 V
Adjustment	Manual or electrical, 12 or 24 V
Adjustment range	Up/down: $>\pm 8^\circ$ - left/right: $>\pm 8$
Mirror mounting bracket	Clamp for 18-22 or 28 mm tube diameter
On-board power supply connection	2 or 6-pin female socket, additional options upon request
Material	Shock-proof ABS plastic, black, UV resistant

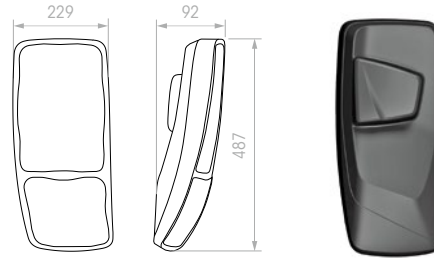

Item No.	Mount	Adjustment	Heating	Connection
51.1036.007.001	left side, horizontal	manual	unheated	
51.1036.008.001	right side, horizontal	manual	unheated	
51.1036.003.001	left side, vertical	manual	unheated	
51.1036.004.001	right side, vertical	manual	unheated	
51.1036.009.001	left side, horizontal	electrical	heated, 12 V	6-pin female socket
51.1036.010.001	right side, horizontal	electrical	heated, 12 V	6-pin female socket
51.1036.005.001	left side, vertical	electrical	heated, 12 V	6-pin female socket
51.1036.006.001	right side, vertical	electrical	heated, 12 V	6-pin female socket

Additional product options upon request

Combination mirror 1036

Color options
(Other colours possible)

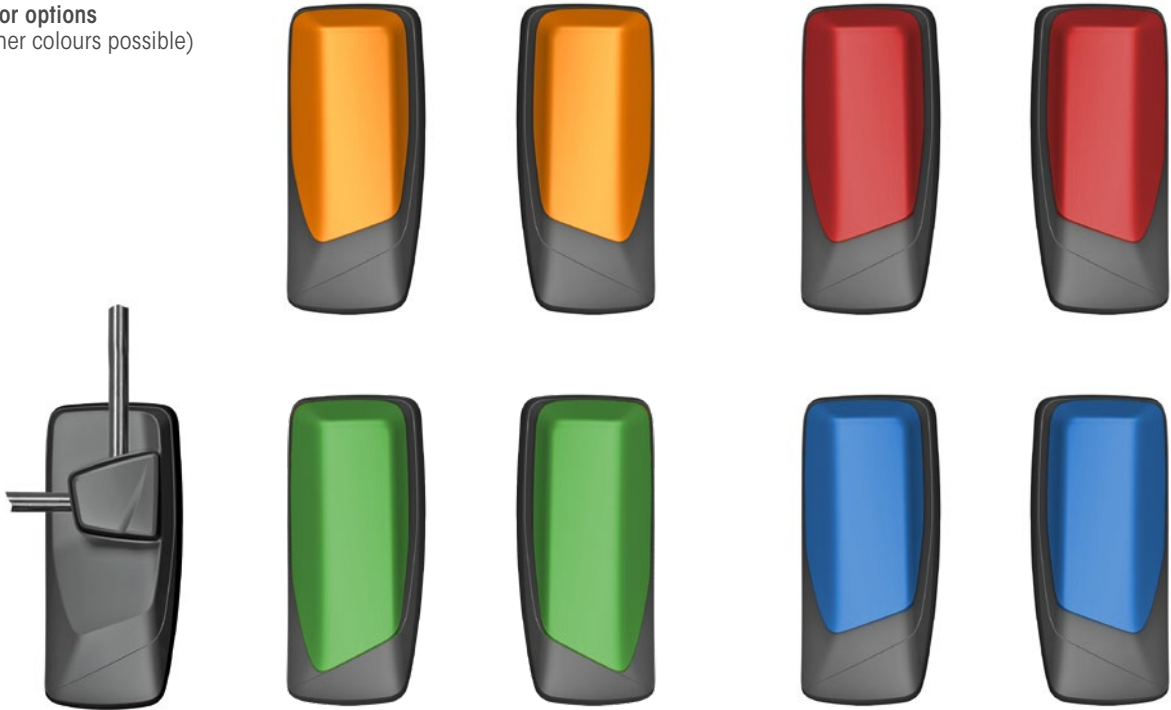

Mirror Systems

Modular Mirrors



Modular mirror 1009, accredited for field-of-vision class II

Glass size	Main mirror 225 x 286 mm (W x H), close-proximity mirror 178 x 91 mm (W x H)	
Radius of curvature	Main mirror 1200 mm, Close-proximity mirror 240/300 mm	
Mounting side	Right and left	
Heating	Unheated or heated, 12 or 24 V	
Adjustment	Manual or electrical, 12 or 24 V	
Adjustment range	Up/down: >±8° - left/right: >±8°	
Mirror mounting bracket	Clamp for 18-22 mm tube diameter	
On-board power supply connection	2 or 6-pin female socket, direct contact connection and additional options upon request	
Material	Shock-proof ABS plastic, black, UV resistant	

Item No.	Mount	Adjustment	Heating	Connection
Main mirror ¹				
51.1009.001.001	right and left side	manual	unheated	
51.1009.081.001	right and left side	manual	heated, 12 V	2-pin female socket
51.1009.113.001	right and left side	electrical	heated, 12 V	6-pin female socket
Main and close-proximity mirror combination ²				
51.1009.017.001	right and left side	manual	unheated	
51.1009.049.001	right and left side	manual	heated, 12 V	2-pin female socket
51.1009.097.001	right and left side	electrical	heated, 12 V	6-pin female socket
Extra large close-proximity (tractors) ³				
51.1009.021.099	left side	manual	unheated	
51.1009.022.099	right side	manual	unheated	
51.1009.121.099	left side	electrical	heated, 12 / 24 V	6-pin female socket
51.1009.122.099	right side	electrical	heated, 12 / 24 V	6-pin female socket
Extra large close-proximity (Radbagger) ⁴				
51.1009.242.099	right side	manuell	unheated	

Additional product options upon request



Basic Line 1038

Glass size	Main mirror 232 x 168 mm (W x H), Close-proximity mirror 114 x 159 mm (W x H)
Wölbungsradius	Hauptspiegel 1200 mm, Nahbereichsspiegel 200 +25 mm
Mounting side	Right or left
Heating	optional on request
Adjustment	Manual
Adjustment range	Up/down: $>\pm 10^\circ$ - left/right: $>\pm 10^\circ$
Mirror mounting bracket	Clamp for 22 mm tube diameter, Direct mounting with two screws
Material	Shock-proof ABS plastic, black, UV resistant

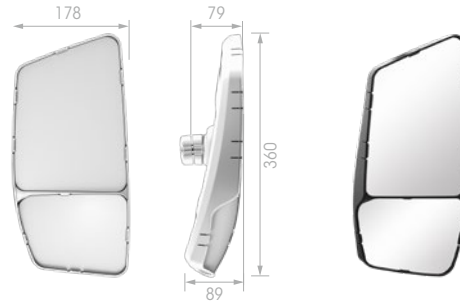

Item No.	Mount	Adjustment	Heating	Connection
51.1038.003.001	left side	manual	unheated	
51.1038.004.001	right side	manual	unheated	

Additional product options upon request

Mirror Systems

Compact, Main and Wide-angle mirrors

Compact mirror 1010, accredited for field-of-vision class II

Glass size	Main mirror 169 x 277 mm (W x H)
Radius of curvature	1200 mm
Mounting side	Right and left
Heating	Unheated or heated, 12 V
Adjustment	Manual
Adjustment range	Up/down: $>\pm 9^\circ$ - left/right: $>\pm 9^\circ$
Mirror mounting bracket	Clamp for 14-20 mm or 18-22 mm tube diameter
On-board power supply connection	-
Material	Shock-proof ABS plastic, black, UV resistant

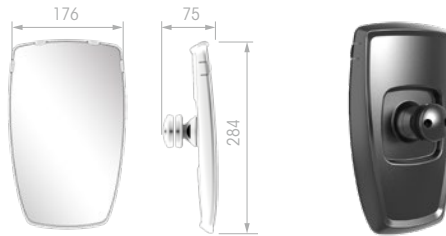

Item No.	Montage	Adjustment	Heating	Radius of curvature
for 14-20 mm tube diameter 1				
51.1010.010.001	right and left side	manual	unheated	spherical
for 18-22 mm tube diameter 2				
51.1010.001.001	right and left side	manual	unheated	aspherical

Additional product options upon request



Main mirror 348, accredited for field-of-vision class II

Glass size	190 x 375 mm (W x H)
Radius of curvature	1200 mm
Mounting side	Right and left
Heating	Heated, 24 V, unheated upon request
Adjustment	Manual
Adjustment range	Up/down: $>\pm 10^\circ$ - left/right: $>\pm 10^\circ$
Mirror mounting bracket	Clamp for 22 mm tube diameter
On-board power supply connection	2 or 6-pin female socket, direct contact connection upon request
Material	Shock-proof ABS plastic, black, UV resistant

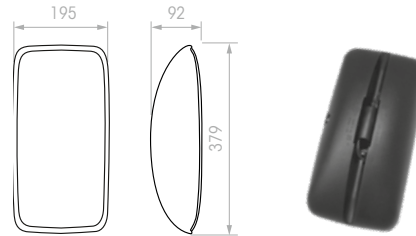

Item No.	Mount	Adjustment	Heating	Connection
61.3480.149 H	right and left side	manual	heated, 24 V	

Additional product options upon request

Wide-angle mirror 348, accredited for field-of-vision class IV

Glass size	191.5 x 191.5 mm (W x H)
Radius of curvature	300 mm
Mounting side	Right and left
Heating	Heated, 24 V, unheated upon request
Adjustment	Manual
Adjustment range	Up/down: $>\pm 10^\circ$ - left/right: $>\pm 10^\circ$
Mirror mounting bracket	Clamp for 22 mm tube diameter
On-board power supply connection	2-pin female socket, direct contact connection upon request
Material	Shock-proof ABS plastic, black, UV resistant

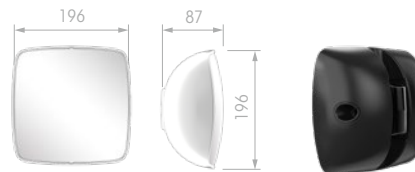

Item No.	Mount	Adjustment	Heating	Connection
61.3482.149 H	right and left side	manual	heated, 24 V	2-pin female socket

Additional product options upon request

Mirror Systems

Main and Wide-angle Mirrors

Main mirror 363, accredited for field-of-vision class II

Glass size	185 x 363.5 mm (W x H)
Radius of curvature	1200 mm
Mounting side	Right and left
Heating	Unheated or heated, 12 or 24 V
Adjustment	Manual or electrical, 12 or 24 V
Adjustment range	Up/down: $>\pm 7^\circ$ - left/right: $>\pm 13^\circ$
Mirror mounting bracket	Clamp for 20-28 mm tube diameter
On-board power supply connection	2 or 6-pin female socket, direct contact connection upon request
Material	Shock-proof ABS plastic, black, UV resistant

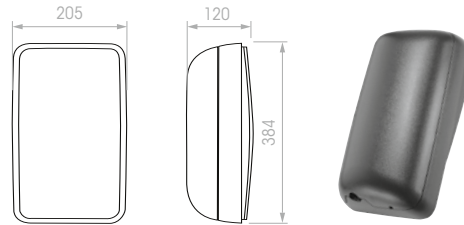

Item No.	Mount	Adjustment	Heating	Connection
51.3635.201	left side	manual	unheated	
51.3636.201	right side	manual	unheated	
51.3635.204	left side	manual	heated, 24 V	2-pin female socket
51.3636.204	right side	manual	heated, 24 V	2-pin female socket
51.3635.206	left side	electrical	heated, 24 V	6-pin female socket
51.3636.206	right side	electrical	heated, 24 V	6-pin female socket

Additional product options upon request

Wide-angle mirror 906, accredited for field-of-vision class IV

Glass size	198 x 189 mm (B x H)
Radius of curvature	300 mm
Mounting side	Right and left
Heating	Unheated or heated, 12 or 24 V
Adjustment	Manual
Adjustment range	Up/down: $>\pm 10^\circ$ - left/right: $>\pm 10^\circ$
Mirror mounting bracket	Clamp for 20-28 mm tube diameter
On-board power supply connection	2-pin female socket, direct contact connection upon request
Material	Shock-proof ABS plastic, black, UV resistant

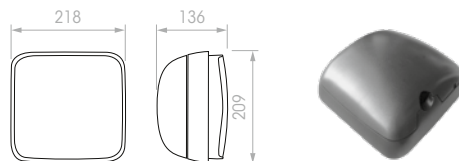

Item No.	Mount	Adjustment	Heating	Connection
56.9065.132	right and left side	manual	unheated	
56.9065.110	right and left side	manual	heated, 24 V	2-pin female socket

Additional product options upon request

Wide-angle mirror 386-1, accredited for field-of-vision class IV

Glass size	149 x 198 mm (W x H)
Radius of curvature	400 mm
Mounting side	Right and left/right or left
Heating	Unheated or heated, 12 or 24 V
Adjustment	Manual or electrical, 12 or 24 V
Adjustment range	Up/down: $>\pm 6^\circ$ - left/right: $>\pm 8^\circ$
Mirror mounting bracket	Clamp for 20-28 mm tube diameter
On-board power supply connection	2 or 6-pin female socket, direct contact connection upon request
Material	Shock-proof ABS plastic, black, UV resistant

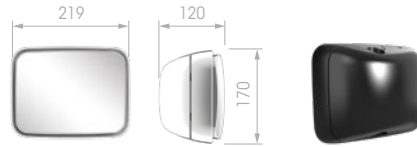

Item No.	Mount	Adjustment	Heating	Connection
56.3860.212	right and left side	manual	unheated	
56.3860.214	right and left side	manual	heated, 24 V	2-pin female socket
56.3861.116H	left	electrical	heated, 24 V	6-pin female socket
56.3862.116H	right	electrical	heated, 24 V	6-pin female socket

Additional product options upon request

Wide-angle mirror 386-2, accredited for field-of-vision class IV

Glass size	149 x 198 mm (W x H)
Radius of curvature	300 mm
Mounting side	Right and left
Heating	Unheated or heated, 24V
Adjustment	Manual
Adjustment range	Up/down: $>\pm 10^\circ$ - left/right: $>\pm 10^\circ$
Mirror mounting bracket	Clamp for 20-28 mm tube diameter
On-board power supply connection	2-pin female socket, direct contact connection upon request
Material	Shock-proof ABS plastic, black, UV resistant

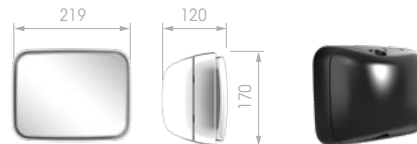

Item No.	Mount	Adjustment	Heating	Connection
56.9065.132	right and left side	manual	unheated	
56.9065.110	right and left side	manual	heated, 24 V	2-pin female socket

Additional product options upon request

Mirror Systems

Main, Wide-angle and Close-proximity Mirrors

Main mirror 572, accredited for field-of-vision class II

Glass size	179 x 405 mm (W x H)
Radius of curvature	1200 mm
Mounting side	Right and left/right or left
Heating	Unheated or heated, 12 or 24 V
Adjustment	Manual or electrical, 12 or 24 V
Adjustment range	Up/down: $>\pm 10^\circ$ - left/right: $>\pm 10^\circ$
Mirror mounting bracket	Clamp for 22, 24 or 28 mm tube diameter
On-board power supply connection	2- or 6-pin female socket, direct contact connection and additional options upon request
Material	Shock-proof ABS plastic, gray, UV resistant

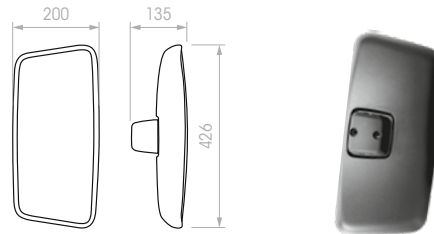

Item No.	Mount	Adjustment	Heating	Connection
for 22 mm tube diameter				
51.5720.120 H	right and left side	manual	unheated	
51.5720.140 H	right and left side	manual	heated, 24 V	2-pin female socket
51.5721.160 H	left	electrical	heated, 24 V	6-pin female socket
51.5722.160 H	right	electrical	heated, 24 V	6-pin female socket
for 28 mm tube diameter				
51.5720.127 H	right and left side	manual	unheated	

Additional product options upon request

Wide-angle mirror 573, accredited for field-of-vision class IV

Glass size	177 x 182 mm (W x H)
Radius of curvature	300 mm
Mounting side	Right and left
Heating	Unheated or heated, 24V
Adjustment	Manual
Adjustment range	Up/down: $>\pm 10^\circ$ - left/right: $>\pm 10^\circ$
Mirror mounting bracket	Clamp for 22, 24 or 28 mm tube diameters
On-board power supply connection	2 or 6-pin female socket, direct contact connection upon request
Material	Shock-proof ABS plastic, gray, UV resistant

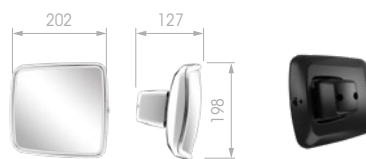

Item No.	Mount	Adjustment	Heating	Connection
for 22 mm tube diameter				
56.5730.120	right and left side	manual	unheated	
56.5730.140	right and left side	manual	heated, 24 V	2-pin female socket
for 28 mm tube diameter				
51.5733.001	right and left side	manual	unheated	

Additional product options upon request

Close-proximity mirror 1005, accredited for field-of-vision class V

Glass size	322 x 190 mm (W x H)
Radius of curvature	300 mm
Mounting side	Top
Heating	Unheated or heated, 24 V
Adjustment	Manual
Adjustment range	Up/down: $>\pm 10^\circ$
Mirror mounting bracket	2 x M6; 50 mm hole spacing
On-board power supply connection	2-pin female socket, direct contact connection upon request
Material	Shock-proof ABS plastic, black, UV resistant

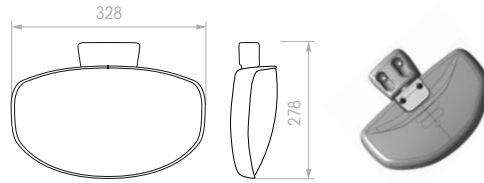

Item No.	Mount	Adjustment	Heating	Connection
Options				
59.1005.005.001	top	manual	unheated	
59.1005.004.001	top	manual	heated, 24 V	2-pin female socket

Mirror Systems

Close-proximity Mirrors

Close-proximity mirror 552, accredited for field-of-vision classes V+ VI

Glass size	310 x 180 mm (W x H)
Radius of curvature	300 oder 400 mm
Mounting side	Universal
Heating	Unheated or heated, 24 V
Adjustment	Manual
Adjustment range	Up/down: $>\pm 10^\circ$
Mirror mounting bracket	Clamp for 18-22 mm tube diameter
Interface	Ball stud and tube connection, customized for vehicle or mounting system, additional options upon request ²
On-board power supply connection	2 or 6-pin female socket, direct contact connection upon request
Material	Shock-proof ABS plastic, gray, UV resistant

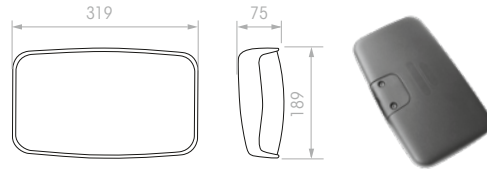

Item No.	Mount	Adjustment	Heating	Connection
300 mm radius of curvature; for ball studs ¹				
51.5524.930	universal	manual	unheated	
51.1009.113.001	right	electrical	heated, 24 V	2-pin female socket
300 mm radius of curvature, bolted, with mounting base ¹				
59.5524.530 H	right and left side	manual	unheated	
400 mm radius of curvature, for ball studs ³				
51.5524.940	universal	manual	unheated	

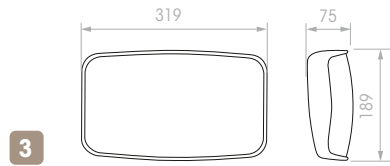

Close-proximity mirror 558, accredited for field-of-vision classes V + VI

Glass size	257 x 154 mm (W x H)
Radius of curvature	300 mm
Mounting side	Universal
Heating	Unheated
Adjustment	Manual
Adjustment range	Up/down: $>\pm 10^\circ$
Interface	Ball stud and tube connection, customized for vehicle or mounting system, additional options upon request 1
On-board power supply connection	-
Material	Shock-proof ABS plastic, black, UV resistant

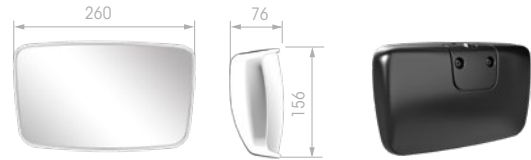

Item No.	Mount	Adjustment	Heating	Connection
Option				
51.5589.100	universal	manual	unheated	



1 24 mm dia. or 28 mm dia.

Close-proximity mirror 559, accredited for field-of-vision classes V+ VI

Glass size	248 x 157 mm (W x H)
Radius of curvature	240 mm
Mounting side	Universal
Heating	Unheated
Adjustment	Manual
Adjustment range	Up/down: $>\pm 10^\circ$
Interface	Ball stud and tube connection, customized for vehicle or mounting system, additional options upon request 1
On-board power supply connection	-
Material	Shock-proof ABS plastic, black, UV resistant

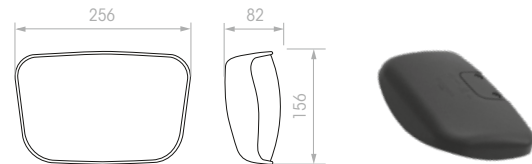

Item No.	Mount	Adjustment	Heating	Connection
Option				
51.5590.020	universal	maunal	unheated	



1 24 mm dia. or 28 mm dia.

Mirror Systems

Close-proximity Mirrors

Close-proximity mirror 360, accredited for field-of-vision class V

Glass size	272 x 162 mm (W x H)
Radius of curvature	300 oder 400 mm
Mounting side	Universal
Heating	Unheated or heated, 24V
Adjustment	Manual
Adjustment range	Up/down: $>\pm 15^\circ$
Interface	Bolted, 2 x M8, through bracket
On-board power supply connection	2-pin female socket, direct contact connection upon request
Material	Shock-proof ABS plastic, gray, UV resistant

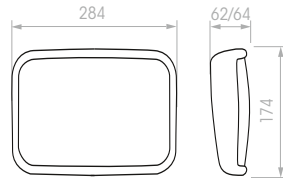

Item No.	Hole spacing	Mount	Adjustment	Heating	Connection
300 mm radius of curvature 1					
59.3601.178	100 mm	universal	manual	unheated	
59.3601.188	100 mm	universal	manual	heated, 24 V	2-pin female socket
59.3604.178	50 mm	universal	manual	unheated	
400 mm radius of curvature 2					
59.3601.128	100 mm	universal	manual	unheated	
59.3604.128	50 mm	universal	manual	unheated	







Mounting Systems



Telescopic mirror rod 1038	70
Telescopic mirror rod 1017	71
Mirror mounting system 1045	72
Mirror mounting system 1016	73
Mirror mounting system 270A/271	74
Wedge mounts for mirror mounting system 270A/271	75
Mirror mounting system 270-7	75
Mirror mounting systems 1007 and 1011	76
Individual components	77

Mounting Systems

Universal Solutions

Mounting System 1038

Radius	Manually adjustable: 425 to 675 mm
Tube diameter	22 mm
Mounting side	Right or left, bolted down
Adjustment	One working position, in the rest
Folding torque	56 Nm
Vehicle interface	Bolted, 2 x M8, through bracket
Wiring	Hidden wiring available, 2/6-pin female socket or open ends
Material	Plastic mounting base, powder-coated tubular steel, black

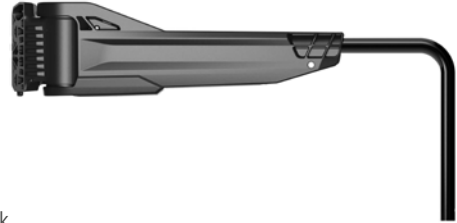

Item No.	Mount	Adjustment	Heating	Wiring
Manual rod adjustment				
58.1038.003.099	left	manual	unheated	no cable
58.1038.004.099	right	manuell	unheated	no cable

Telescopic mirror rod 1017

Radius	Option a: manually adjustable - 510 to 800 mm Option b: electrically adjustable - 510 to 760 mm
Tube diameter	22 mm
Mounting side	Right and left, bolted down
Adjustment	One working position, foldable in both directions
Folding torque	60 Nm
Vehicle interface	Bolted, 2 x M8, through bracket
Wiring	Hidden wiring, 2/6-pin female socket or open ends
Material	Pressure-molded aluminium, powder-coated tubular steel, black



Item No.	Mount	Adjustment	Heating	Wiring
Manual rod adjustment 1				
58.1017.005.001	left side	manual	unheated	no cable
58.1017.006.001	right side	manual	unheated	no cable
58.1017.013.001	left side	manual	heated	plug-in
58.1017.014.001	right side	manual	heated	plug-in
58.1017.011.001	left side	electrical	heated	plug-in
58.1017.012.001	right side	electrical	heated	plug-in
Electrical rod adjustment 2				
58.1017.015.001	left side	electrical	heated	plug-in
58.1017.016.001	right side	electrical	heated	plug-in
With entry light 3				
customized	left side/right side	manual/electrical	heated/unheated	plug-in

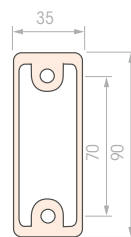

Mounting Systems

Universal Solutions

Complete system 1017: with mirrors 1036 and 1009

Mirrors also available separately



1036 see page 56



1009 see page 58

Horizontal attachment possible



Further variants upon request

Mounting System 1045

Radius	470 mm
Tube diameter	22 mm
Mounting side	Right and left, bolted down
Adjustment	One working position, foldable in both directions
Folding torque	120 Nm
Vehicle interface	Bolted, 2 x M8, through bracket
Wiring	Hidden wiring available
Material	Pressure-molded aluminium, powder-coated tubular steel, black



Item No.	Mount	Adjustment	Heating	Wiring
Options				
customized	left	manual	unheated	no cable
customized	right	manuell	unheated	no cable

Mirror mounting system 1016

Maximum radius	500 mm
Tube diameter	22 mm
Mounting side	Right or left, mounting system bolted down
Folding mechanism	Manual, all bracket angles 30°
Folding torque	25 Nm
Vehicle interface	Mounting base
Wiring	Open or hidden wiring available, 2/6-pin female socket or open ends
Material	Pressure-molded aluminium, powder-coated tubular steel, black

Item No.	Mount	Option
U-shaped tubular bracket 1		
58.1016.001.001	left side	a)
58.1016.002.001	right side	a)
58.1016.003.001	left side	b)
58.1016.004.001	right side	b)
L shaped tubular bracket 2		
58.1016.009.001	left side	a)
58.1016.010.001	right side	a)
Z shaped tubular bracket 3		
58.1016.005.001	left side	a)
58.1016.006.001	right side	a)

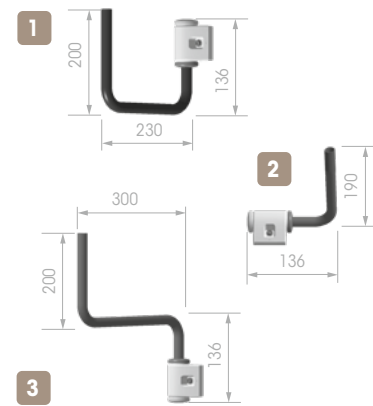
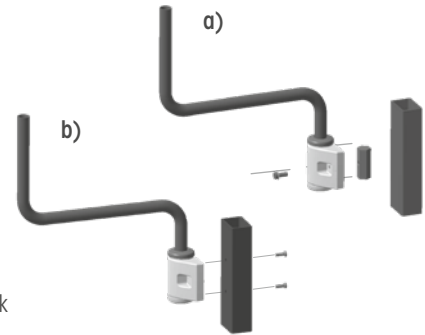

Customized tube design available

Mounting base bolted via hex attachment

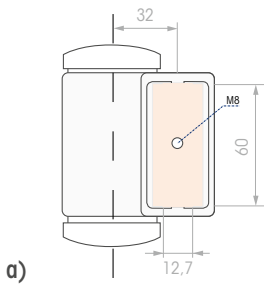

Mounting base bolted on directly

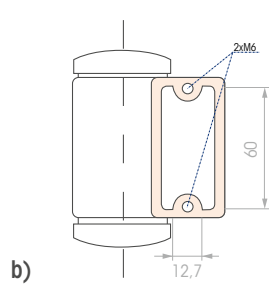

Mounting sides can be switched, tube orientation will change as shown below:

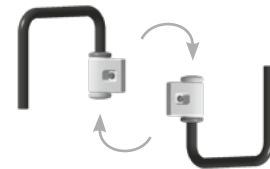

Mounting Systems

Universal Solutions

Mirror mounting system 270A/271

Maximum radius	700 mm
Tube diameter	28 mm
Mounting side	Right or left, removable mounting system
Adjustment	Manual, 30°, 45°, 52°, 60°, 72° bracket angles
Folding torque	30-120 Nm
Vehicle interface	Wedge mount 248-2 A/271 A
Wiring	Open or hidden wiring available, 2/6-pin female socket, open ends, or direct contact connection
Material	Powder-coated tubular steel, black



Dove tail guide

Item No.	Mount	Adjustment	Heating	Wiring
Dimensions: 256 x 450 mm (W x H), 90° bracket angle, including control cable and wedge mount 1				
58.2704.051 H	universal	manual	mirror heating	plug-in
Dimensions: 160 x 500 mm (W x H), 90° bracket angle, including heating cable and wedge mount 2				
58.2704.048	universal	manual	mirror heating	plug-in
Dimensions: 676 x 327 mm (W x H), 6° bracket angle, including control cable 3				
58.2704.093	universal	electrical	mirror heating	direct contact connection



Wedge mounts for mirror mounting system 270A/271

Size	Varying
Design	For plug-in or direct contact connection
Attachment	4 mounting points for M8 Allen screws
Material	Powder-coated, pressure-molded aluminium, black

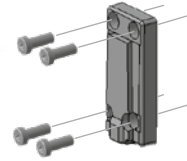

Item No.	Mount	Adjustment	Heating	Wiring
Wedge mount 248-2 A for plug-in connection, 50 x 108 x 15 mm (W x H x D) 1				
20.2480.210	universal	manual	-	no cable
20.2480.221	universal	electrical	mirror heating	plug/cable 2.5 m
Wedge mount 271 A for direct contact connection, 59 x 124 x 21 mm (W x H x D) 2				
20.2710.640	universal	electrical	mirror heating	plug-in

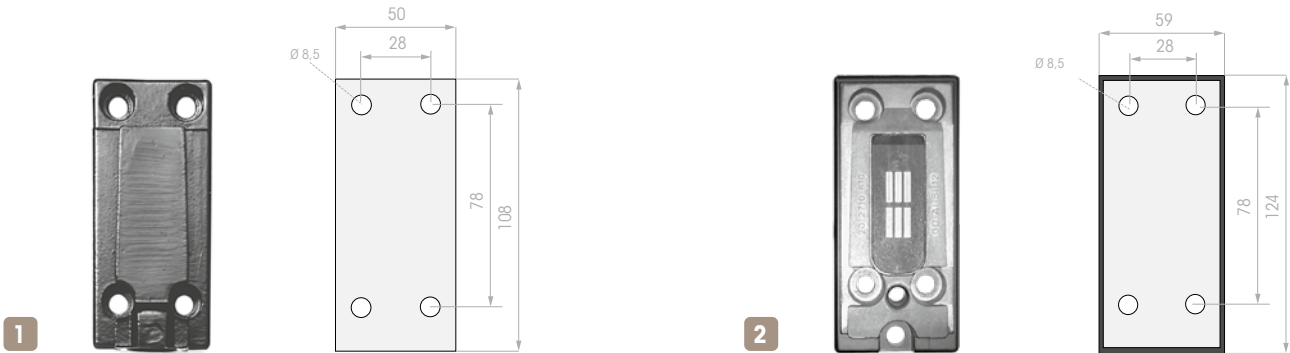

Mirror mounting system 270-7

Maximum radius	600 mm
Tube diameter	28 mm
Mounting side	Right and left, mounting system bolted down
Adjustment	Manual, 51.4° bracket angle
Folding torque	75 Nm
Vehicle interface	2 x M8 for bolting from inside of cab
Wiring	Open or hidden wiring available, for heated and/or unheated electrically adjustable mirrors
Material	Powder-coated tubular steel, black



Customized tube design available



Mounting Systems

Universal Solutions

Mirror mounting system 1007 and 1011

Maximum radius	700 mm
Tube diameter	28 mm/40 mm
Mounting side	Right and left, mounting system bolted down
Adjustment	Manual, 52° bracket angle
Folding torque	60 Nm
Vehicle interface	Insertion into rectangular tube
Wiring	Open or hidden wiring available, 2/6-pin female socket or open ends
Material	Pressure-molded aluminium, powder-coated tubular steel, black



Customized tube design available



Individual components

Item No.	Wiring	Control
Heating cable with plug		
09.2070.101 1	2-pin oval right-angle connector - open end, length 2.07 m	-
09.2000.301 2	2-pin round right-angle connector - open end, length 2.0 m	-
Control cable with integrated heating lead		
09.3200.310 3	6-pin round right-angle connector - 2.8 crimp, length 2.0 m	for one mirror
09.3200.320 4	6-pin round right-angle connector - 6.3 crimp, length 2.0 m	for two mirrors
Power-supply line for mirror switch		
09.3200.210 5	open end - 2.8 crimp, length 1.0 m	for one mirror
09.3200.220 6	open end - 6.3 crimp, length 1.0 m	for two mirrors
Mirror switch		
08.3200.233 7	12 and 24V on-board voltage, size: 42 x 42 x 54 mm (W x H x D)	for two mirrors
Complete kit for electrically adjustable mirrors		
09.3200.420 H 6 4 4		



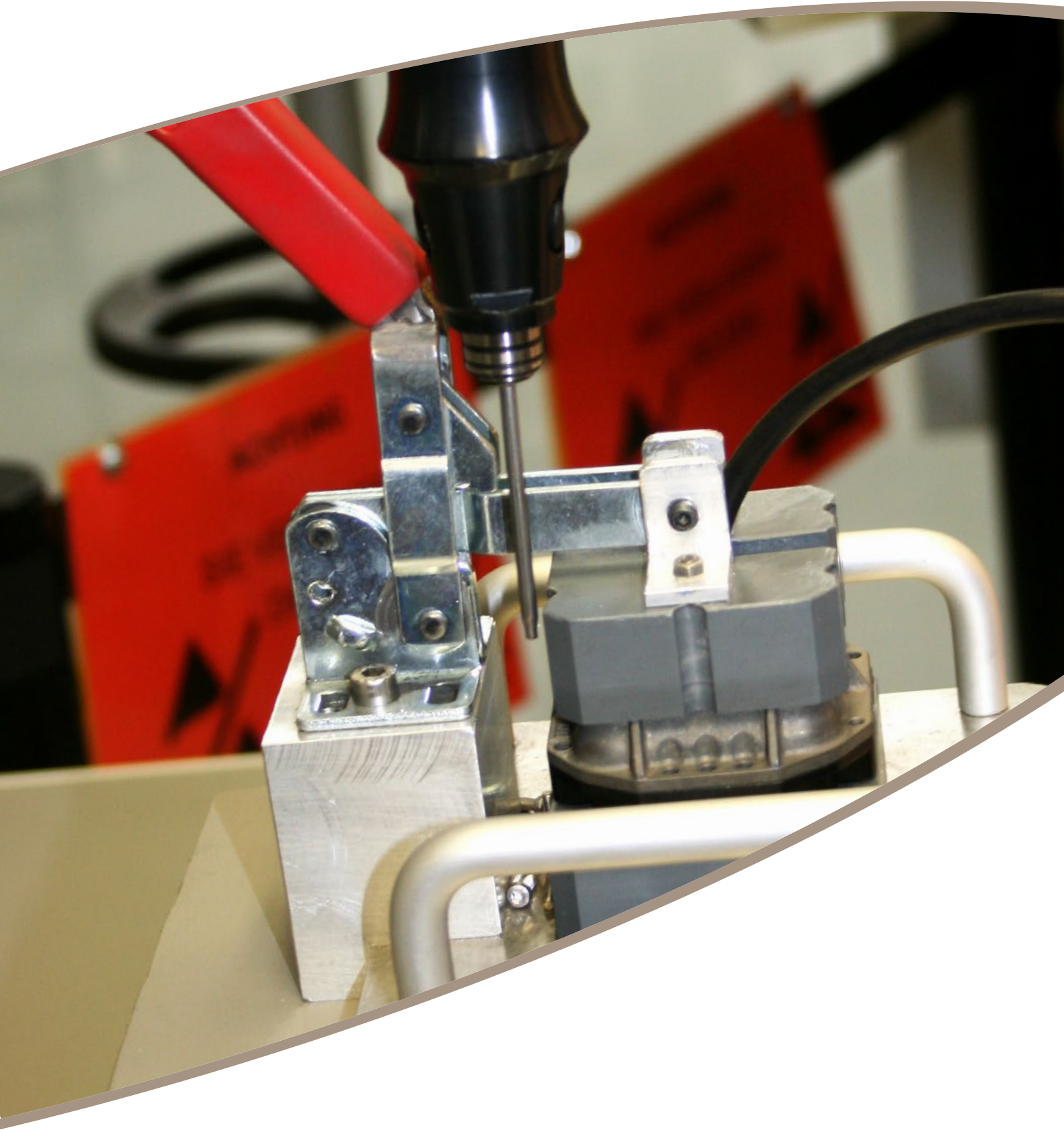

Electronics



Camera overview	80
Analog platform cameras	81
Digital platform cameras	82
Platform camera brackets	83
Shutter camera bracket	84
Monitor overview	85
Accessories	86

Our new generation of cameras is based on a high-quality modular development platform allowing the implementation of customized solutions in a camera that is perfectly tailored to our customers' requirements.

With installed dimensions of 35 x 35 mm, the extremely rugged camera components are highly compact. The length of the camera varies with the individual models, however, the minimum length of every model is 34 mm which makes it easy to integrate and attach almost anywhere in or on the vehicle. **The modular design allows for a wide variety of image sensors as well as image processing and transmission technologies to be combined, providing a customized and cost effective solution uniquely adapted to the individual needs of the customer.**

The available image sensors are automotive-grade and offer image resolutions from standard VGA up to 1.2 mega pixels. The image processor is matched to the performance characteristics of the specific image sensor. Transmission technology options include analog PAL or NTSC based video transmission as well as digital transmission standards such as Fast Ethernet or BroadR-Reach.

It is also possible to combine the platform components with various lenses providing different horizontal aperture angles. Aperture angles for analog options include 70°, 100°, and 120°, and for digital options 100°, 120°, 160°, and 176° (wider aperture angles are also supported).

The MEKRA Lang platform camera features a particularly rugged housing which makes it perfectly suited for rough environmental conditions. And thanks to its high-performance integrated heating system, which de-ices the lens within just a few minutes, the camera can be operated under all weather conditions.



Electronics

Analog Platform Cameras

Analog camera 1307

Video system	NTSC or PAL
Image display	NTSC: 720 x 486 pixels (W x H), PAL: 720 x 576 (W x H)
Aperture angle	50°, 70°, 100° or 120°
Shock resistance	50 G
Min. illumination	Contrast ratio >1:50 at 0,5 lux
Video output	FBAS 1Vss at 75 Ω
Power consumption	< 1 W (< 3.5 W, with heating system ON)
Operating temperature	-40 °C to +85 °C
Storage temperature	-40 °C to +90 °C
Ingress protection	IP 69 K
Operating voltage	9-36 V



Item No.	Aperture Angle	Mount
NTSC color camera		
28.1307.004.199	70°	horizontal
28.1307.005.199	100°	horizontal
28.1307.006.199	120°	horizontal
28.1307.011.199	100°	low distortion, horizontal
PAL color camera		
28.1307.001.199	70°	horizontal
28.1307.002.199	100°	horizontal
28.1307.003.199	120°	horizontal
28.1307.010.199	120°	low distortion, horizontal

Electronics

Digital Platform Cameras

Ethernet camera 1309

Video transmission	UDP or RTP
Video compression	MJPEG or H.264
Sensor resolution	1280 x 720 pixels (WxH)
Image display	45 Hz to 1280 x 960 pixels, 60 Hz to 1280 x 720 pixels
Image sensor	1.2 mega pixels
Aperture angle	50°-100°, 80°-176°
Shock resistance	50 G
Min. illumination	Contrast ratio >1:50 at 0,5 lux
Power consumption	< 1 W (< 3.5 W, with heating system ON)
Operating temperature	-40 °C to +85 °C
Storage temperature	-40 °C to +90 °C
Ingress protection	IP 69 K
Operating voltage	9- 6 V



Item No.	Aperture Angle	Mount
Digital platform camera		
28.1309.040.199	50°-100°	horizontal
28.1309.041.199	80°-176°	horizontal

Advantages of the platform camera

- Very compact - camera can be easily integrated in the vehicle body, roof, mirror, etc.
- Higher resolution - sharper image (digital camera)
- Each camera can be controlled separately (digital camera)
- Reduced network wiring requirements result in cost savings (digital camera)
- Digital signals may be used for additional information purposes (digital camera)
- Digital camera can control additional components, e.g. our shutter camera bracket
- Platform concept allows for quick and easy adjustments

Electronics

Platform Camera Brackets

Platform camera brackets

Mounting bracket with protective hood

Dimensions 53 x 58 x 58 mm (W x H x D)
Material Stainless steel



Item No.

11.1307.028.099

Ball bracket

Dimensions 80 x 71 x 42 mm (W x H x D)
Orientation Fully adjustable as needed
Adjustment Thanks to its swivel head design, the camera can be rotated 0°-360°
Material ABS plastic



Item No.

11.1307.027.099

Magnetic Base

Dimensions 66 x 66 x 19 mm (W x H x D)



Item No.

20.5640.101

Electronics

Shutter camera bracket with integrated LED lamp

Shutter camera bracket with integrated LED lamp

Dimensions	114 x 96 x 107 mm (W x H x D)
Adjustment	Camera is rigid within bracket; several options for mounting positions, see below
Material	ABS plastic
Operating temperature	-40 °C to + 85 °C
Operating voltage	12-24 V
Ingress protection	IP 67



Item No.

11.1307.029.099

Shutter camera bracket mounting positions



Advantages of the shutter camera bracket

- Camera protection
- Improved night vision
- Rugged design
- Shutter camera bracket and gears are decoupled from one another
- Very high IP rating (IP 67 = can be submerged in water for 30 minutes)
- Shutter camera bracket can be used with both analog and digital cameras
- Lateral cable routing
- One second opening time and one second closing time

Electronics

Monitor Overview

Our camera monitor systems will increase your efficiency and safety at work. A properly installed system with all components securely attached can help minimize property damage and prevent personal injuries. It also comes with significant ergonomic advantages and better comfort.

Its rugged design withstands even the most extreme conditions and its range of global applications is virtually unlimited.



Various monitor brackets



TFT color monitors

MEKRA Lang 7" surround view monitor

- Dimensions: 189 x 119 x 44 mm (W x H x D)
- Images can be rotated 90°, 180°, and 270°
- Display modes are freely configurable
- Multiple trigger signals can be employed
- Up to 9 views are freely configurable
- Kit includes sun visor, bracket, and connecting cable (24.1301.512))



Item No.

On request

MEKRA Lang 7" TFT-LCD quad monitor IP 65

- Dimensions: 189 x 119 x 44 mm (W x H x D)
- Picture-in-picture (PiP) display
- Up to 4 camera inputs can be selected
- Up to 4 trigger signals can be employed
- Kit includes sun visor, bracket, and connecting cable (24.1301.501)



Item No.

On request

Electronics

Accessories



Maximized adaptability...

MEKRA Lang cameras can be directly connected to existing vehicle displays, and MEKRA Lang camera systems are compatible with most third-party displays. Let us find out for you whether that is the case for your display. (Additional systems upon request.)

Command Center - MEKRA (f)



1x Fendt - MEKRA (f)



Trimble - MEKRA (f)



Case BNC - MEKRA (f)



Appendix

Space for your creative ideas



General Terms and Conditions

Last Update: 06/2024

I. General Provisions

The contractual relationship between us, MEKRA Lang GmbH & Co. KG ("MEKRA Lang"), and our ordering parties ("Purchasers"), who are entrepreneurs as defined in § 14 BGB (German Civil Code), is solely governed by the General Terms and Conditions of Sale and Delivery (AGB) set out below. Dissenting terms and conditions of the Purchaser, even if known to us, shall not form part of the contract. Our offers shall be non-binding at all times. Our General Terms and Conditions of Sale and Delivery shall be regarded as accepted upon order placement, at the latest upon acceptance of the goods. In the case of an on-going business relationship, these General Terms and Conditions of Sale and Delivery shall also apply to all subsequent transactions. The invalidity of any provision of these general terms and conditions, in whole or in part, shall not affect the validity of the remaining provisions. In this case, MEKRA Lang and the Purchaser shall agree on provisions that shall be suitable to implement the economic purpose of the invalid provisions to the greatest extent possible. Until such time, the relevant legal provisions shall apply.

II. Contract Conclusion and Prices

1. By ordering goods the Purchaser bindingly states the wish to purchase the goods ordered. This statement shall remain binding for a period of two weeks. We shall be entitled to accept the submitted contract offer within a period of two weeks after receipt thereof. Acceptance may be declared in writing, electronically, or by delivery of the goods to the Purchaser.
2. The obligations pertaining to electronic commerce set forth in § 312e Sec. 1 sentence 1 Nos. 1 to 3 and sentence 2 BGB shall be excluded.
3. The conclusion of the contract shall be subject to orderly and timely receipt of goods from our own suppliers. This shall apply only, if we cannot be held responsible for the non-delivery, especially if we have entered into a congruent coverage transaction with our own suppliers. The Purchaser shall be informed of the non-availability of the goods or services without delay, and any compensation that has already been paid shall be reimbursed immediately.
4. All payments to be made hereunder shall be made in Euros.
5. All prices quoted shall be net ex works or distribution warehouse, respectively. Freight, packaging and import costs, as well as customs duties and other ancillary expenses shall be payable by the Purchaser.

III. Delivery Time and Delivery Obligation

1. Extent, type, and time of delivery shall be subject to our written or electronic order confirmation. Partial deliveries shall be permissible.
2. Any obligation to comply with delivery deadlines deemed as binding shall be conditional on the undisturbed flow of operations and distribution processes; particularly in cases of force majeure and other disruptive events at our facilities or those of our suppliers or carriers, including but not limited to operational or traffic disruptions, fire, flooding, labor, energy, or traffic shortages, strikes, lockouts, acts of public authorities as well as technical or technological conditions that considerably impede the execution of the contract, shall release us from the obligation to deliver on time or entitle us to suspend delivery without any obligation for subsequent delivery.
3. Unless otherwise agreed, we shall be entitled to deliver before a stated delivery date. Additionally, unless otherwise agreed, any delivery of up to two weeks past a stated delivery date shall not be regarded as delayed on our end.
4. When the goods have left the factory or distribution warehouse or the Purchaser has received notice of our readiness to deliver by the time the delivery dates expire, said delivery dates shall be regarded as met. Subsequent contract amendments shall provide for reasonable delivery date extensions.
5. Where the performance of a contract consists of multiple deliveries, the non-fulfillment, improper fulfillment or delayed fulfillment of one delivery shall not affect the other deliveries

pertaining to the contract.

6. Defaults in payment, declarations in lieu of an oath as per § 807 ZPO (German Code of Civil Procedure), emergent payment difficulties or signs of significant deterioration in the Purchaser's financial position shall entitle us, at our discretion, to demand advance payment for deliveries not yet completed, or to call off deliveries immediately and to refuse the fulfillment of current contracts. At the same time, we shall be entitled to make due and payable with immediate effect any accounts receivable from the Purchaser which are not due yet.

IV. Shipping, Transfer of Risk

1. Unless otherwise agreed by the contracting parties, packaging, shipping route and method of transportation remain at our discretion.
2. Upon hand-over, or in case of a sale by dispatch upon delivery of the goods to the forwarding agent, the carrier, or any other person or institution designated to execute the shipment, the risk of accidental loss and accidental deterioration of the goods shall be passed on to the Purchaser. If the Purchaser defaults on acceptance, this shall be deemed equivalent to hand-over.
3. Unless otherwise agreed, goods from call orders shall be accepted within 3 months upon order confirmation.
4. Insurance coverage for breakage and transportation risks shall be taken out upon special request only, and for a corresponding fee.
5. Customs duties and other expenses, including those for obtaining the required import documents for the country of destination, shall be payable by the Purchaser.

V. Payment, Payment Terms

1. Invoices shall be payable:
 - a) within 14 days from the date of invoice including a 2 % cash discount on the final invoice value;
 - b) within 30 days from the date of invoice without a cash discount on the final invoice value.
2. A cash discount shall be granted only, if all payment obligations arising from earlier deliveries have been fulfilled and the invoice amount has been submitted to us in cash or credited to our account in a timely fashion by the aforementioned due dates. As a result, the submission of a bill of exchange cannot lead to the granting of a cash discount. In case of a cashless payment, especially when a check is submitted, the time the amount is credited shall be the determining factor. A cash discount cannot be granted for amounts that are paid or credited conditionally or subject to other limitations. The Purchaser shall assume any and all risks in connection with the method of payment. Invoices for tools shall be payable immediately without cash discount.
3. Bills of exchange and cheques shall be accepted on account of performance only. The corresponding amounts shall be credited subject to receipt of the full amount due. We reserve the right to accept other or own acceptances. Expenses and discount charges shall be payable by the Purchaser. We shall assume no responsibility for submission and protest. If the Purchaser's own bills of exchange have been protested or if protested other bills of exchange not have not been covered immediately, we shall be entitled to return any and all pending bills of exchange. At the same time we shall be entitled to make immediately due and payable those accounts receivable from the Purchaser which are not due yet. Pre-dated checks shall not be accepted.
4. In case of missed payment dates, interest on defaulted payment of 9 % above the base rate of the German Central Bank according to § 247 BGB shall be payable, as well as damages due to late performance in the amount of € 40.00 according to § 288 Sec. 5 BGB. We shall continue to reserve the right of assertion of further damages due to late performance and other claims.
5. Advance and interim payments shall be non-interest bearing.
6. The Purchaser shall be entitled to offset or withhold payment only if the counterclaim is undisputed or has been determined

legally binding. The Purchaser may execute a right of retention only if his counter claim is based on the same contractual relationship.

7. When settling invoices, the Purchaser shall provide the respective customer and invoice numbers. Any costs due to delays or accounting errors resulting from a failure to do so, shall be borne by the Purchaser.

VI. Retention of Title, Factoring

1. We shall retain full title to the goods that have been delivered, until such time as any and all receivables arising from the business relationship with the Purchaser have been paid. The Purchaser shall be entitled to resell the goods to which we have retained title within the ordinary course of business; however, any pledging or security transfer shall not be permissible. Where the goods to which we have retained title are being resold on credit, the Purchaser must ensure that our rights are protected.
2. The Purchaser hereby assigns to us any of the Purchaser's receivables arising from the resale of the goods to which we have retained title in the amount invoiced; we hereby accept such assignment. Regardless of the assignment, the Purchaser shall retain the right to collect payment, provided that he fulfills his obligations owed to us according to the underlying contractual relationship and does not fall into financial decline. Otherwise the Purchaser shall, upon our request, provide any information about the assigned receivables that are required for collection, and shall notify his debtors of the assignment. In this case we shall reserve the right to collect the receivables on our own.
3. Any finishing or processing of the goods to which we have retained title by the Purchaser shall be performed on our behalf and by our order, however, without resulting in any obligations for us. If the goods to which we have retained title are processed with goods that are third-party property, then we shall acquire co-title to the new goods. The proportion of co-title shall follow from the proportion of the value of the goods to which we have retained title and the value of the other processed goods. Any references herein to the value of the goods to which we have retained title shall be based on our invoice value.
4. Should the Purchaser acquire sole ownership of the new goods according to § 947 Sec. 2 BGB, it is agreed that the Purchaser shall grant us co-title to the new goods in proportion of the value of the processed, combined, or mixed goods to which we have retained title, and shall remain custodian of the goods which shall be free of charge.
5. Where the goods to which we have retained title are resold together with other goods, regardless of whether or not they were processed, combined or mixed, the advance assignment agreed to above is valid only to the extent of the value of the goods to which we have retained title that were resold together with the other goods. If requested, we shall release the securities we are entitled to as provided above, insofar as the value exceeds the claims to be secured by 20 %.
6. The Purchaser shall immediately notify us of any third-party compulsory execution measures regarding the goods to which we have retained title or the receivables assigned in advance and shall provide us with any documents required for an intervention. Any related intervention costs shall be payable by the Purchaser.
7. The Purchaser shall take out adequate fire and burglary insurance for the goods to which we have retained title and shall provide us with corresponding proof, if requested.

VII. Warranty Claims

1. The period of limitation for warranty claims is 24 months from the delivery of the goods.
2. Initially, we shall remedy any defects in the products through either reworking or replacement (at our discretion). Where defects cannot be remedied through reworking or replacement, the Purchaser shall have the right to demand a cancellation of the contract or a reduction in compensation. However, the

Purchaser shall not be entitled to cancel, if the lack of conformity is minor, and particularly if the defects are minor.

3. The Purchaser must notify us in writing of any obvious defects without delay, at the latest within 7 days after receipt of the goods, suspending any processing immediately. Otherwise the assertion of any warranty claims shall be excluded. The timely dispatch of the notification shall be deemed sufficient for compliance with the notification period. The full burden of proof regarding all requirements for asserting claims shall be borne by the Purchaser, especially for the defect itself, for the time of the establishment of the defect, and for the timeliness of the complaint regarding the defect.
4. Defects which, despite careful inspection, cannot be ascertained within this time period are to be reported to us in writing immediately upon discovery. If, after a failed cure, the Purchaser opts for a withdrawal from the contract due to a legal or material defect, the Purchaser shall not also be entitled to seek damages based on the defect.
5. If, after a failed cure, the Purchaser opts for damages, the goods shall remain with the Purchaser, if this can be reasonably expected. Damages are limited to the difference between the purchase price and the value of the defective product. This shall not apply if we caused the contract violation maliciously.
6. Title to all goods for which we provided replacement, will pass to us and such goods shall be returned to us for a reimbursement of costs.
7. No claims may be asserted for damages which were negligently caused by the Purchaser through
 - a) improper handling or excessive use of the purchased item, or
 - b) unauthorized modification of the purchased item, or
 - c) non-compliance with the assembly or operating instructions, or
 - d) a breach of the complaint and delivery obligations according to para. 3 and 4 above, or
 - e) continued use of the purchased item after the defect has been ascertained. Ordinary wear and tear shall be excepted from the warranty.

VIII. Liability

1. In case of slightly negligent breaches of duty, our liability shall be limited to the average immediate damage that can be reasonably and typically expected for the respective contract type. The aforementioned shall also apply to slightly negligent breaches of duty by our legal representatives or agents. We shall not be held liable in case of a slightly negligent breach of nonessential contract obligations.
2. Any liability based on assumed warranties as well as product liability shall remain unaffected, including for bodily harm or health impairments attributable to us or loss of life of the Purchaser.
3. The period during which the Purchaser shall be entitled to claims for damages due to a defect is limited to one year from delivery of the goods. The aforementioned shall not apply, if we can be accused of willful intent or gross negligence, as well as bodily harm or health impairments attributable to us or loss of life of the Purchaser.
4. Notice Regarding Market Surveillance: As a distributor and importer, you play an important part in ensuring the compliance and safety of products in the market. As a distributor and importer of our products, you are required to comply with the applicable legal provisions and obligations regarding market surveillance, should there be any indications of discrepancies (e.g. in the form of complaints regarding non-compliance with ECE R46 or general, safety-related issues). Please adhere to the corresponding reporting requirements in connection with the above-mentioned anomalies. Any reports to us should be comprised of transparent and verifiable information. Please contact your sales team representative.

IX. Returns

As a rule, returns of goods that were properly ordered and delivered shall not be accepted. Returns that have been arranged with us shall be the exception. In addition, the following prerequisites must be met:

1. The products must have been purchased directly from us or from one of our factory warehouses.
2. The goods must be in flawless and unaltered condition.
3. As a rule, we shall accept returned goods or parts only if they are still part of our current product portfolio.
4. Returns must be shipped „free domicile“ to our plant in Ergersheim or to the appropriate factory warehouse and must include the respective delivery note dates and numbers. Value reduction for returns:
 - in the 1st year after delivery date ./ 10 % of the contract price
 - in the 2nd year after delivery date ./ 25 % of the contract price
 - between the 3rd and the 5th year after delivery date ./ 50 % of the contract price
 - Any goods older than 5 years may not be returned.Upon receipt of the parts, a technical inspection shall be performed and a credit slip completed, taking into account any applicable value reductions. The remaining value shall be reduced by any original shipping costs incurred by us.

X. Intellectual Property Rights

1. Regarding custom-made products, the Purchaser shall be liable to us for the exemption from third-party intellectual property rights in connection with the items ordered, shall indemnify us against any possible third-party claims and shall compensate us for any damages resulting from a breach of this obligation.
2. Our designs and design proposals shall be kept confidential and may not be passed on to third parties.
3. Any drawings, construction plans, and samples provided to the Purchaser shall remain our intellectual property.

XI. Place of Fulfillment, Jurisdiction, Other Agreements

1. As a rule, it shall be considered agreed that the condition of the goods is solely set forth in our product description. Any public statements, sales talks, or advertisements by us shall not represent a contractual description of the condition of the goods. Samples and specimens shall serve as approximate illustrative articles regarding product quality, dimensions and color and cannot serve as the basis for asserting any legal claims. We reserve the right to make reasonable technical changes as well as modifications in shape, color, and/or weight.
2. If the Purchaser receives inaccurate assembly instructions, we shall only be obliged to provide accurate assembly instructions, and only, if the inaccurate assembly instructions prevent proper assembly.
3. We shall not grant any warranties in the legal sense to the Purchaser; the aforementioned shall not affect any manufacturer's warranties.
4. The place of fulfillment for our deliveries ex works shall be the delivery plant; the place of fulfillment for our deliveries ex stock shall be the warehouse. The place of fulfillment for any payments shall be Ergersheim in Bavaria, Germany.
5. The exclusive place of jurisdiction for any disputes regarding this contract shall be Fürth in Bavaria, Germany. This shall also apply to lawsuits regarding checks or bills of exchange.
6. The law of the Federal Republic of Germany shall govern these provisions. The provisions of the UN United Nations Convention on Contracts for the International Sale of Goods shall not apply. The German-language version of these General Terms and Conditions of Sale and Delivery shall apply exclusively.
7. The special terms of our products published with the appropriate price lists shall apply as well.
8. The Purchaser shall be responsible for examining the suitability of the goods for their intended use.
9. In accordance with the provisions of the German Federal Data Protection Law (BDSG), we wish to note that all Purchaser data required for order processing will be stored electronically.

MEKRA Lang - **passion** for excellence.

Corporate Headquarters

MEKRA Lang GmbH & Co. KG

Buchheimer Str. 4

91465 Ergersheim

www.mekra.de

Contents are subject to change.

Last Update: October 2025

